

Microwave-Assisted Extraction for the Isolation of Trace Systemic Fungicides from Woody Plant Material

by

Stephanye Dawn Armstrong

Dissertation submitted to the Faculty of the Virginia Polytechnic Institute and State University in partial fulfillment of the requirements for the degree of

DOCTOR OF PHILOSOPHY

In
Chemistry

APPROVED:

Dr. Harold McNair, Chairman
Dr. R.J. Stipes
Dr. Harold Bell
Dr. James O. Glanville
Dr. Brian Tissue

April 1, 1999
Blacksburg, Virginia

Key Words: MAE, Sample Preparation, GC-MS, Fungicides and Wood Tissue

Microwave-Assisted Extraction for the Isolation of Trace Systemic Fungicides from Woody Plant Material

By

Stephanye Armstrong

Department of Chemistry

Virginia Polytechnic Institute and State University

(ABSTRACT)

The extraction and recovery of trace organic material from semi-solid and solid matrices is often the slowest and most error-prone step of an analytical method. The conventional liquid extraction techniques for solids and semi-solids materials (Soxhlet) have two main disadvantages. The first, large volumes of organic solvent are required, which can lead to sample contamination and “losses” due to volatilization during concentration steps. The second, to achieve an exhaustive extraction can require several hours to days. With the development of sophisticated instrumentation with detection limits in the picogram and femtogram levels, pressure is finally felt within the analytical community to develop and validate sample preparation procedures which can be used to rapidly isolate trace level organics from complex matrices.

Because of its applicability to solid, semi-solid, and liquid matrices microwave-assisted (MAE) extraction has emerged as a powerful sample preparation technique. The objective of this research was to evaluate directly focused microwave energy for the isolation of systemic fungicide residues from woody plant tissues.

The hallmark of microwave extraction (MAE) is accelerated dissolution kinetics as a consequence of the rapid heating processes that occur when a microwave field is applied to a sample. The current popularity of MAE resides mainly on its applicability to a wide range of sample types because the selectivity can be easily manipulated by altering solvent polarities.

Propiconazole is a systemic fungicide, used to combat the fungal pathogen *Ophiostoma ulmi*, the casual agent of Dutch elm disease (DED). It was successfully extracted from treated *Ulmus americana* (elm tree) using MAE with a percent recovery of $\geq 95\%$ in 15 minutes. Until now, techniques for rapid and efficient extraction of polar material from wood were non-existent. This work produces results much quicker than Supercritical Fluid Extraction (SFE). The influence of pH, microwave power, and time on extraction efficiency was also investigated. The extraction methodology was optimized and statistically validated.

This MAE method combined with GC-MS was used to study the diffusion patterns and degradation of propiconazole in tree bark over extended time periods. Because of the complex nature of woody plant systems, it was realized that a more theoretical means must be used to determine the degradation rate of propiconazole in water systems. As a result, propiconazole was reacted with water under controlled temperature and pH conditions; to measure the degradation rate of propiconazole.

The internal pH of elm sap is about 6.0; the slightly acidic environment and natural enzymes within the xylem vessels are known to catalyze the degradation of propiconazole (1). Novartis Inc. has marketed propiconazole as having fungicidal effects in injected elms for nearly two years. Our degradation studies have indicated much shorter lifetimes. To confirm our fate studies, the activation energy for the degradation reaction of propiconazole was calculated. This information provided valuable insight into revising dosage and treatment frequency for maximum protection of the elm against Dutch elm disease. Anti-fungal activity among metabolites was also explored.

This is the first reported use of MAE to monitor the degradation of systemic pesticides in woody plant material.

Dedication

This work is dedicated to my sisters Carol, Vicki, Monique, Roslynn, Brigitte, Charlene, and Daria in appreciation for their unconditional love and acceptance.

Acknowledgments

I would like to thank my advisor, Professor Harold M. McNair for playing a very critical role in my personal and professional development

I am also very grateful to Dr. R.J. Stipes and Dr. Herman Warren not only for their academic direction but also for their friendship. During my life, I have had many chance encounters with people who have left indelible impressions on my life, but none as great as the two of you.

I also owe a major debt of gratitude to Dr. Brian Tissue and Dr. James O. Glanville. Thank you, for the technical assistance and support that you both provided me during my tenure as a student at Virginia Tech. But most of all, I appreciate your encouragement and kindness.

I would also like to extend my sincerest appreciation to Dr. Harold Bell and Dr. Gary Long for their helpful corrections.

Larry, I am extremely grateful to you for all the hard work you put into updating the mass spectrometer computer. Thank you for always being willing to help me. I also would like to thank you for being a good friend, listener, and counselor. Thank you!

Gail, I really appreciate everything you have done to make life in the laboratory enjoyable for me. On a more personal note, for the last two years you were Virginia Tech for me! And I will sorely miss having you as a part of my everyday life. I wish you the best that life can offer.

I would be horribly remiss if I did not take the opportunity to thank friends, family, and colleagues for their love and support. They are: Daria Lawson-Little, Dr. Laretta E. King, The Giovanni Family, Mary Warren, Karen Stipes, Dr. Yuwen Wang, Vicki Hutchinson, The Hinton Family, Soror Mary Calloway, Dr. R.L. Grayson, Dr. Benjamin Dixon, Dr. James Holland, Saint Paul's African Methodist Episcopal Church, Asbury United Methodist Church and Dr. Astor Herrell.

Table of Contents

Abstract	Page ii
Dedication	iv
Acknowledgments	v
Table of Contents	vi
List of Figures	ix
List of Equations	xi
List of Tables	xii
I. Introduction	1
II. Literature Review	
A. Introduction	11
B. Soxhlet Extraction	12
C. Thermal Desorption	15
D. Supercritical Fluid Extraction	19
E. Accelerated Solvent Extraction	21
F. Microwave Extraction	23
III. Quantitative Analysis of <i>Ulmus americana</i> treated with Propiconazole by Microwave Extraction and Thermal Desorption	
A. Introduction	32
B. Experimental Conditions-MAE	33
1. Wood Preparation	33
2. Spiking Procedure	33
3. Microwave Instrumentation	34
4. Extraction Procedure	34
5. Analysis of Extracts-GC/MS	35
a. Quantitation	36
b. Limit of Detection and Quantitation	37
C. Results and Discussions	
1. Effects of Microwave Energy on Wood Xylem Cells	38
2. GC/MS Analysis	40
3. MAE	
a. Solvent	41
b. Time	44
c. Power	46

d. pH	51
e. Correction Factors	53
D. Experimental Conditions-Thermal Desorption	
1. Wood Preparation	55
2. Extraction Procedure	55
E. Results	57
F. Conclusion	59
1. Comparison of MAE and Thermal Desorption	60
IV. Residual Fate Studies of Propiconazole	
A. Introduction	61
B. Experimental	
1. Trees	66
2. Injection Procedure	66
3. Sampling	68
4. Sample Preparation	68
5. Microwave-Assisted Extraction	69
6. GC Analysis	69
7. Quantitation	69
C. Results and Discussion	
1. Translocation Rate	71
2. Distribution	71
3. Residual Levels	75
4. Duration	77
D. Conclusion	87
V. Degradation Studies of Propiconazole	
A. Introduction	88
B. Experimental	
1. Standard Preparation	91
2. Degradation Conditions	91
3. Extraction Conditions	92
4. Analysis	94
5. Kinetic Experiments	94
C. Results and Discussions	96
1. Half-lives	99
2. Activation Energy	100
3. Degradation Products	102
D. Conclusions	107
VI. General Conclusions	108
VII. Literature Cited	111
VIII. Appendix I: Data from Chapter IV	117

List of Figures

	Page
1. Elm Bark Beetle Feeding in Twig Crotch	2
2. Healthy Xylem Vessel	3
3. Diseased Xylem Vessel	3
4. Hyphae of <i>Ophiostoma ulmi</i>	4
5. Transverse View of Xylem Vessels: Tyloses and Discoloration	5
6. Structure of Thiabendazole	6
7. Pyrogram of Thiabendazole	7
8. Structure of Propiconazole	8
9. Diagram of Soxhlet Extractor	13
10. Schematic of Thermal Desorption Unit	16
11. Schematic of ASE/SFE Instrumentation	22
12. Effects of Microwave Energy on H ₂ O	26
13. Schematic of Closed-Vessel System	28
14. Schematic of Focused-Microwave Instrumentation	30
15. Transverse View of Healthy Xylem Cells	38
16. Transverse View of Microwaved Xylem Cell	39
17. Lateral View of Non-treated Xylem Pits	39
18. Lateral View of Microwaved Xylem Pits	40
19. GC/MS Analysis of Propiconazole	41
20. Effects of Solvent on Extraction Efficiency	43
21. Influence of Time on Recovery	45
22. Effects of Power on Recovery	47
23. Effects of Power and Time on Recovery	48
24. Samples Extracted at Powers of 120W and 90W for 15 minutes	50
25. The Effect of pH on % Recoveries	52
26. Extraction Profile of Propiconazole	54
27. Pyrogram of <i>Ulmus americana</i>	56
28. Comparison of Desorption Temperatures	58
29. Thermal Desorption versus Microwave-Assisted Extraction	60
30. Example of Macro-Injection	63
31. Example of Micro-Injection	64
32. Zone of Inhibition	65
33. Calibration Curve	70
34. Average Distribution of Propiconazole in 10 mL Micro-injected Elms	72
35. Average Distribution of Propiconazole in 10 mL Macro-injected Elms	73
36. Average Distribution of Propiconazole in 20 and 40 mL Elms	74
37. Structure of Cellulose	76
38. Diffusion Pattern of Elm 1	78
39. Diffusion Pattern of Elm 2	79
40. Diffusion Pattern of Elm 3	80
41. Diffusion Pattern of Elm 4	81

42. Diffusion Pattern of Elm 5	82
43. Diffusion Pattern of Elm 6	83
44. Diffusion Pattern of Residential Elm 20 mL	84
45. Diffusion Pattern of OS Elm 20 mL	85
46. Diffusion Pattern of Residential Elm 40 mL	86
47. Proposed Degradation Pathway of Propiconazole	89
48. Liquid-Liquid Extraction of Propiconazole from Water	93
49. Rate Constants for Isomer-1	97
50. Rate Constants for Isomer-2	98
51. Arrhenius Plot	101
52. Total Ion Chromatogram	102
53. Confirmation of Degradation Product	103
54. Experimental Degradation Pathway	104
55. Total Ion Chromatogram of Water Sample	104
56. Library Comparison of Pentanediol	105
57. Chromatogram of Degradation Product (Enlarged)	106
58. Mass Spectrum of Shoulder	106
59. Mass Spectrum Illustrating the Disappearance	107

List of Equations

	Page
1. Ideal Gas Law	19
2. Arrhenius Equation	23
3. Dissipation Factor	24
4. Estimated Final Temperature	26
5. Limit of Detection	36
6. Limit of Quantitation	36
7. Correction Factors	52
8. First-order Degradation	95
9. Second-order Degradation	95
10. Half-life for a second-order reaction	95
11. Activation Energy	100

List of Tables

	Page
1. Solvent Dielectric Constants	25
2. Heating Rate and Viscosity for Various Solvents	27
3. Limit of Detection and Quantitation	37
4. Average Recoveries and Correction Factors	53
5. Type of Treatment and DBH	67
6. Dosage Information	68
7. Kinetic Data for Isomer 1	99
8. Kinetic Data for Isomer 2	99
9. Blank Data for Elm 1	117
10. 72 Hour Data for Elm 1	117
11. 1 Month Data for Elm 1	117
12. 2 Month Data for Elm 1	118
13. 7 Month Data for Elm 1	118
14. Blank Data for Elm 2	118
15. 72 Hour Data for Elm 2	118
16. 1 Month Data for Elm 2	119
17. 2 Month Data for Elm 2	119
18. 7 Month Data for Elm 2	119
19. Blank Data for Elm 3	120
20. 72 Hour Data for Elm 3	120
21. 1 Month Data for Elm 3	120
22. 2 Month Data for Elm 3	120
23. 7 Month Data for Elm 3	121
24. Blank Data for Elm 4	121
25. 72 Hour Data for Elm 4	121
26. 1 Month Data for Elm 4	121
27. 2 Month Data for Elm 4	122
28. 7 Month Data for Elm 4	122
29. Blank Data for Elm 5	122
30. 72 Hour Data for Elm 5	122
31. 1 Month Data for Elm 5	123
32. 2 Month Data for Elm 5	123
33. 7 Month Data for Elm 5	123
34. Blank Data for Elm 6	123
35. 72 Hour Data for Elm 6	124
36. 1 Month Data for Elm 6	124
37. 2 Month Data for Elm 6	124
38. 7 Month Data for Elm 6	124
39. Blank Data for Old Security Elm	125
40. 72 Hour Data for Old Security Elm	125
41. 1 Month Data for Old Security Elm	125
42. 2 Month Data for Old Security Elm	125
43. 7 Month Data for Old Security Elm	126

44. Blank Data for Ford Elm (20mL)	126
45. 72 Hour Data for Ford Elm (20mL)	126
46. 1 Month Data for Ford Elm (20mL)	127
47. 2 Month Data for Ford Elm (20mL)	127
48. 7 Month Data for Ford Elm (20mL)	127
49. Blank Data for Ford Elm (40mL)	127
50. 72 Hour Data for Ford Elm (40mL)	128
51. 1 Month Data for Ford Elm (40mL)	128
52. 2 Month Data for Ford Elm (40mL)	128
53. 7 Month Data for Ford Elm (40mL)	128

Chapter I

General Introduction

Ophiostoma ulmi, the fungus which causes Dutch elm disease (DED) infects thousands of valuable landscape elms per year. When the disease was first noticed in Europe in 1919, it had already covered most of Belgium, the Netherlands, and was beginning to spread around northern parts of France (2). The misleading name “Dutch elm disease” does not describe the country of origin but was given because all of the early investigations of this fungi were performed by plant pathologists in Holland. Marie Schwarz isolated *O. ulmi* from diseased elms in 1920; inoculated healthy elms with the microorganism and reproduced the disease (3). From this basic research, Schwarz was able to conclude that the isolated fungi was indeed the agent which causes DED. Dr. Christine Busiman later confirmed Schwarz’s work in the early 1930’s (4).

Dutch elm disease was noticed in Cleveland, Ohio in 1930 (5). The fungus was introduced to North America on elm-veneer logs imported from Europe. Within a few years, the disease had spread throughout both the mid-west and northeastern states. Today, infections of DED have been observed in most places that Dutch elms grow. Dutch elm disease is the most destructive shade-tree disease in North America, primarily, because all American species of elm are susceptible to the DED fungus.

In the United States, elms are important for both shade and ornamental purposes. The presence of healthy elm trees increase the property values in residential areas, contributes to aesthetic value of historical sites, and nullify the harshness of the climate extremes.

The fungus is transmitted from diseased to healthy trees primarily by insects. Pathologists have estimated that 85% of new infections are caused by elm bark beetles. The disease can also be transmitted via root grafts and direct connections between trees that have originated as root sprouts.

In the United States, the principal insect carriers of DED fungus are two species of elm bark beetles: the smaller European elm bark beetle, *Scolytus multistriatus* and the native elm bark beetle, *Hylurgopinus rufipes* (6). The beetles distribute the DED fungus

primarily through their feeding process. The beetles feed in the twig crotches of living elm (Fig. 1). If the feeding beetle is carrying the DED fungus on the outside or within their body it can cause a healthy tree to become infected. Spores of *O. ulmi* are introduced into the xylem vessels through those feeding injuries.



Figure 1: Elm Bark Beetle Feeding in a Twig Crotch

Once the fungus is inside the tree, it is transported through the vascular system to other areas inside the tree. Upward movement of the spores is reported to be rapid, whereas, downward movement of the spores is a slow process (7). Since the trees are constantly taking up water from the roots, it is logical that areas in the crown of the tree would be most affected by DED.

Xylem vessels are hollow tubular cells that are the major transporters of water or “sap” (Fig. 2). The xylem cells are connected to each other and to parenchyma cells by openings in the cell wall called “pits”. The presence of these pits facilitates the spread of *O. ulmi* to adjacent xylem vessels because the hyphae of the fungus are able to spread transversely through the pits and longitudinally from vessel to vessel (Fig. 3 and Fig. 4). It is this transport phenomenon, which makes DED so difficult to control.

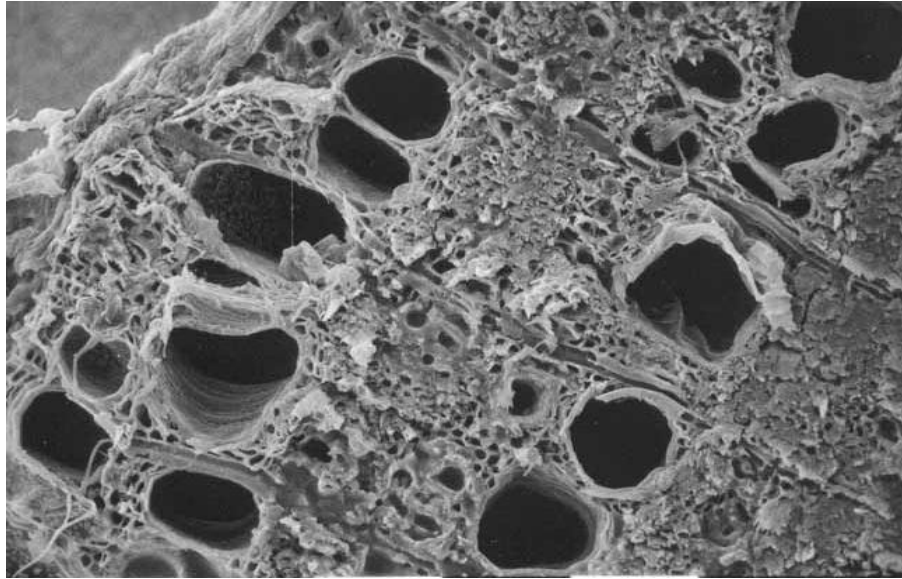

Figure 2: Healthy Xylem Vessels

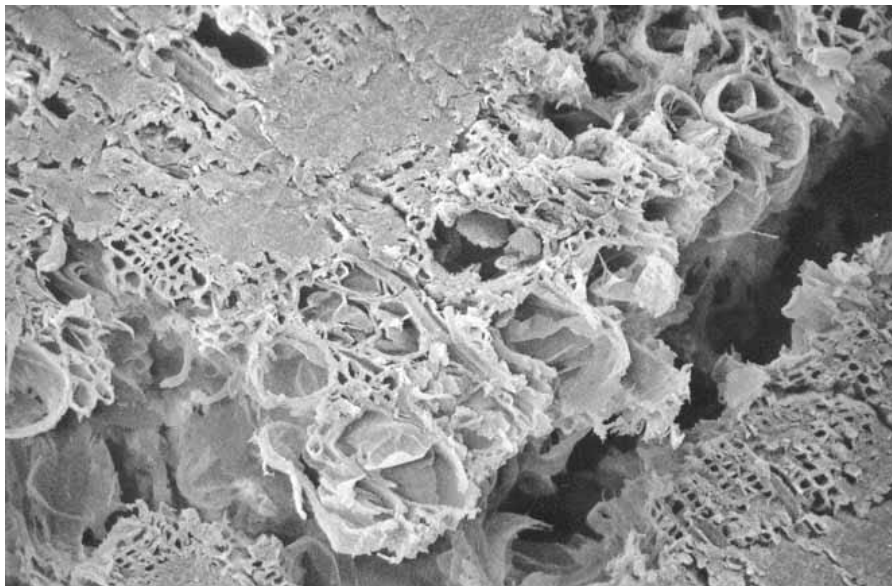

Figure 3: Infected Xylem Vessels

The cell walls of the xylem vessels are designed to act as filters to remove particulate matter such as spores. Survival of the fungal spores then becomes dependent on their ability to produce spores that will successfully pass through the cell wall or grow through the pits (Fig.4).

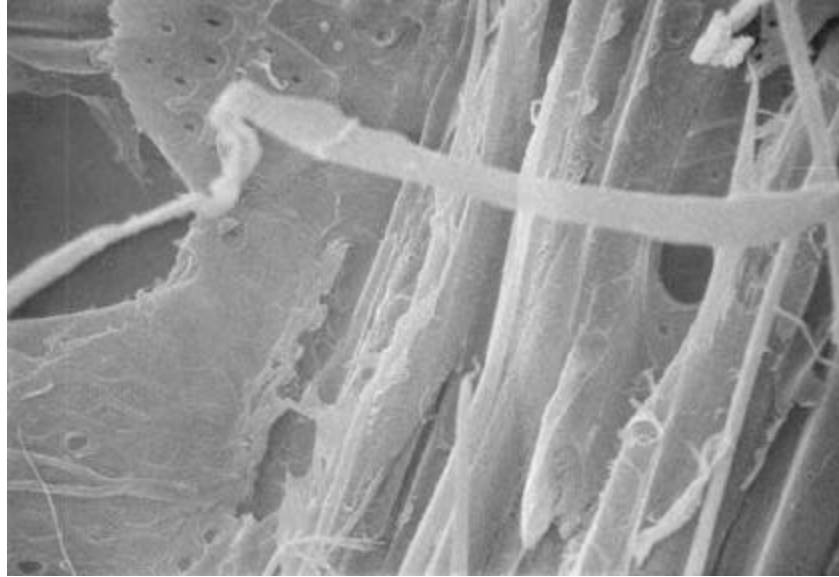

Figure 4: Hyphae of *C. ulmi* Spreading through Xylem Pits

It is curious that the natural defense mechanisms are what eventually causes the death of the tree. To prevent the spread of the invading fungus an injured tree will produce cellulose material called tyloses (Fig. 5). Tyloses are formed by the bulging of adjoining parenchyma cells through pit membranes into the xylem vessels. Several tyloses may grow in a single xylem vessel. The result is restricted movement of water and particulates between adjacent xylem cells. The parenchyma cells also simultaneously secrete phenolic compounds into the xylem cells. These compounds become oxidized and polymerize to form brown pigments (Fig. 5). This discoloration has been used as a marker by arborists to signal the possible presence of DED. It has also been suggested that those phenolic compounds also contribute to water stress by “water-proofing” the cell walls.

These internal defense mechanisms are only effective and non-detrimental when the process of occlusion in infected xylem cells occur rapidly.

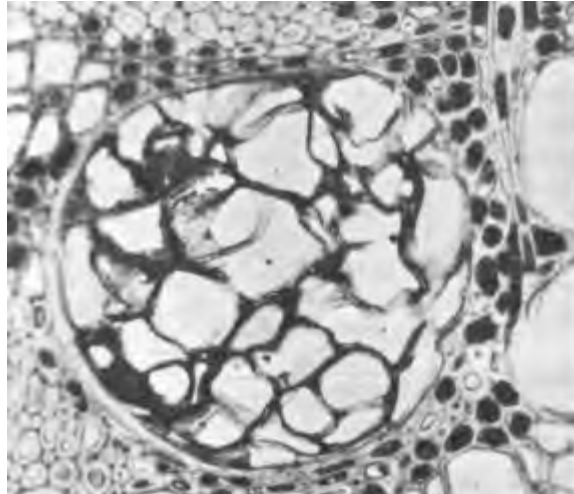

Figure 5: Transverse View of Xylem Cell Blocked by Tyloses (2)

Unfortunately, American elms are highly susceptible to DED; therefore, the host response to *O. ulmi* is delayed (8). The pathogen is able to establish a strong “foot hold” inside the elm so that the entire vascular system is invaded by *O. ulmi*. During a large-scale infection the production of phenolic compounds and tyloses signify that death of the tree is imminent.

The symptoms of the Dutch elm disease vary from dwarfing of the leaves, through various stages of yellowing, and degrees of defoliation, to death of branches; leading to death of the entire tree (9). Elms of all ages are severely affected by DED. The attack is more obvious on young, vigorously growing trees than on old, slower growing trees.

Since Dutch elm disease first appeared in Europe, vigorous efforts have been initiated to eradicate the fungus. Three principal strategies have been employed for the control of Dutch elm disease: planting elms that are resistant to DED, sanitation and chemical treatment.

Sanitation is described as the use of measures to preserve or restore health and to free the environment of agents injurious to health. In the early years, control of DED was attempted by removal and disposal of infected trees to prevent them from spreading spores to adjacent lying trees through the root system and to reduce the number of breeding sites for the elm bark beetles. According to Stipes and Campana, this effort succeeded in limiting the number of trees infected, but not in limiting the area affected by

DED (10). With extensive infections in many areas, this approach was unsuccessful mainly because of the excessive manpower, time, and cost requirements.

The quest for a treatment that would offer mass control of *Ophiostoma ulmi* was abandoned. Emphasis for control shifted to chemical control of the insect carrier and of the pathogen to protect susceptible elms in the landscape.

The initial approach was to reduce the population of *S. multistriatus* and *H. rufipes*. Several eradication techniques were employed by arborists to control the emergence of beetles. The simplest method to kill elm bark beetles was to burn infested wood by May to limit the number of accessible breeding sites (11). Use of biological control agents, such as, woodpeckers to eat the elm bark beetles was also a popular approach. However, the most effective technique used to reduce the population of beetles infected elms involved spraying the bark with a potent insecticide, such as, DDT.

The Environmental Protection Agency banned DDT in 1968 because of its long residual activity, its toxicity to humans and animals, and its resistance to degradation (12). With the emphasis on air pollution and the effects on wildlife many environmentalists argued that spraying the bark of elms with insecticides compounded environmental problems because one would now have to worry about soil, air, and groundwater contamination through both volatilization and run-off. Other pesticides used to protect tree bark from beetles, such as methoxychlor and dieldrin proved to be less effective than DDT. This method of treatment was eventually abandoned in the 1970's. An alternate means of introducing the insecticides and fungicides into the xylem system was sought.

In the early 70's, Kondo and Huntley introduced an injection method of injecting dyes directly into the root flares. Using this technique, uniform distribution, a desirable feature in systemic protection was achieved (13). Application methods now all involve injection directly into the root flares. This technique requires the fungicide or insecticide be dissolved in an aqueous solution to assure easy uptake and uniform distribution in the tree and consequently the greatest opportunity for successful control. Many chemicals have been tested for control of the DED pathogen. Many of the systemic fungicides tested were not ideal for performing trunk injections because there was a small difference

in the concentration levels that are efficacious and those that are phytotoxic (9). This problem was solved with the advent of benzimidazoles.

Presently, benzimidazole fungicides are commonly used to combat a wide variety of agricultural pathogens. Benzimidazole fungicides are popular because they have a high level of toxicity toward many plant pathogenic fungi and low levels of toxicity to plants and mammals (10). Because of their systemic nature they are easily translocated through a diseased plant to the sites of infection.

Thiabendazole, 2-(4-thiazolyl) benzimidazole and Propiconazole, [1-[[2-(2,4-dichlorophenyl)-4-propyl-1,3-dioxolan-2-yl]methyl]-1H-1,2,4-triazole] are broad spectrum systemic fungicides that are the active ingredients of Arbotect® and Tilt®. These fungicides are commonly used to protect elm trees because they exhibit a high degree of activity against *O. ulmi*. The minimal inhibitory concentrations for both thiabendazole and propiconazole are 20 ppm and 1 ppb, respectively. The hypophosphite salts of Thiabendazole and Propiconazole are soluble in water, 2 g/L and 0.5 g/L, and exhibit relatively no toxicity to plant tissues. These two characteristics made them excellent candidates for trunk injections.

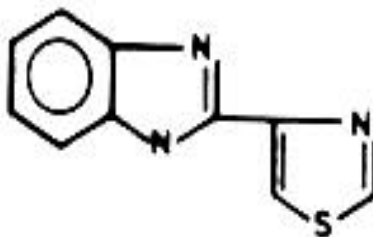

Figure 6: Chemical Structure of Thiabendazole

To date thiabendazole (Fig. 6) has been used extensively in the treatment of DED. Many researchers have reported prophylactic, some therapeutic success and long term residual activity using thiabendazole. Both drenching root systems and injection into the root flares have proven to be very successful using thiabendazole.

Thiabendazole has negligible vapor pressure at room temperature and is very stable in acidic media. Employing plant bioassay tests and zone of inhibition studies the

residual activity of thiabendazole has been reported for as long as 2-3 years after the initial injection into American elm trees. Using the combination of Pyrolysis and Gas Chromatography/Mass Spectrometry (GC-MS) we have been able to detect trace levels of thiabendazole in minced wood samples 1.5 years after application (Fig. 7).

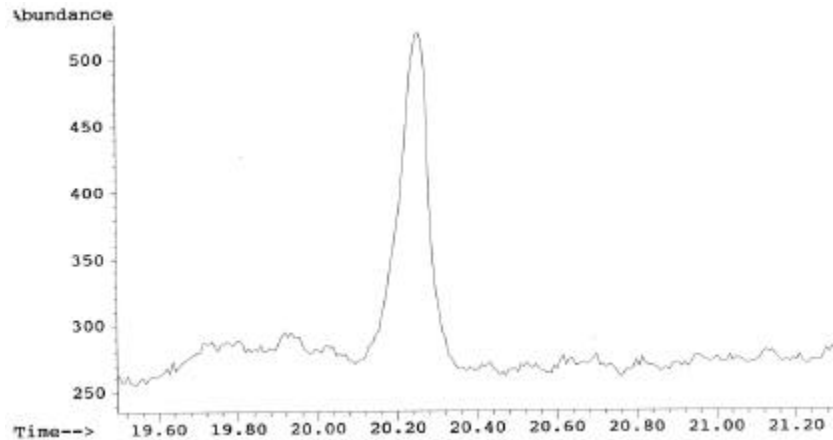

Figure 7: Pyrogram of wood treated with Thiabendazole 1.5 years prior to analysis. The minced wood samples were desorbed for 2 minutes at 290°C. The temperature program was 70°C-1 min-8°C/min-300°C-1min. The column used was a HP-5 (95%-methyl-5%-phenyl polysiloxane) 30 m x .25 µm x .25mm.

The popularity of thiabendazole as an antagonist to *C. ulmi* faded due to the high concentration required to inhibit the growth of *C. ulmi* in wood tissue. To treat an infected tree with thiabendazole it could cost thousands of dollars per treatment depending on the tree size and the stage of infection. This was compounded by the fact that to keep the concentration above the minimal inhibitory level, it could require two or more treatments per year. This is too great an expense to preserve and restore health to elms particularly for residential owners.

Due to the high cost of systemic fungicides it was envisioned that the expense required to control DED employing chemical sanitation programs could be lowered if a more effective fungicide was discovered.

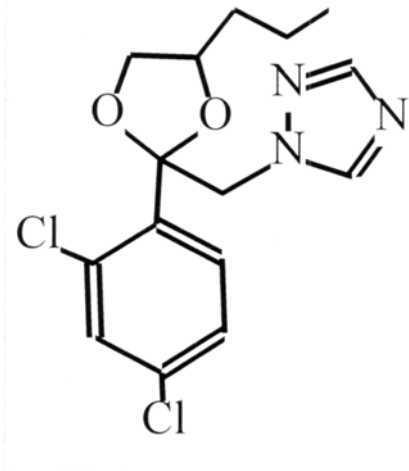

Figure 8: Structure of Propiconazole

The prayers of arborists were thought at first to be answered with the advent of propiconazole. Ciba-Geigy (now Novartis), Agricultural Division (Greensboro, NC), first marketed Propiconazole in the early 1980's as a broad spectrum systemic foliar fungicide with protective and curative action. Propiconazole is an ergosterol biosynthesis inhibitor, which acts as a plant growth regulator. It has anti-fungal activity against powdery mildew, rust, scab, and leaf spot diseases on different crops (11). Initially, propiconazole was not marked as a possible antagonist to *O. ulmi*. Stipes first noticed in 1986, that propiconazole exhibited very strong activity against *O. ulmi*. His research showed that the minimal inhibitory concentration of 1 ppb was lower than any other fungicide tested. This was a significant milestone in the chemical treatment of DED. This breakthrough provided arborists, residential owners, and government agencies with a more economical means of treating Dutch elm disease. Ciba-Geigy, later marketed propiconazole as a preventative and curative agent for the DED pathogen claiming residual activity for 1-2 years. This claim has fueled an on-going debate between arborists and Ciba-Geigy.

When arborists began using propiconazole to treat elms infected with *O. ulmi*; many of them noted therapeutic results but none were able to detect the presence of propiconazole in the treated wood using the zone of inhibition test. One can only imagine how Ciba-Geigy researchers validated their results. How Ciba-Geigy was able to experimentally determine propiconazole residual activity is unknown. They have not

published any relevant data. Because the traditional testing measures failed; no arborist was able to establish direct correlation between the presence of the propiconazole with the therapeutic results observed.

Because of propiconazole's high *in vitro* activity against *O. ulmi* we believed that it was worth pursuing other methods to determine the concentration levels of propiconazole in treated wood. This research describes for the first time a fast method for isolating trace levels of propiconazole from woody plant material with good precision using directly focused Microwave-Assisted Extraction (MAE).

This work consists of six chapters. Chapter I is the general introduction. Chapter II reviews the extraction techniques both past and present used for extraction of wood. Chapter III describes the optimization of the extraction procedures for thermal desorption and microwave-assisted extraction and the statistical comparison of each technique. All extracts were analyzed using selected-ion monitoring GC-MS. The GC/MS conditions were also optimized at this stage.

In Chapter IV, we used our developed method to study the diffusion patterns and the degradation rate of propiconazole *in situ*. It was hoped that this study would provide insight into the residual activity of propiconazole and uniformity of distribution. In this chapter we also discussed the effects of macro-injection versus micro-injection and compared the translocation rates associated with each infusion technique.

As we became more involved with the treatment and sampling procedure it became increasingly obvious that we needed to explore other ways of determining the degradation rate of propiconazole because of the variability of concentration from tree to tree. Chapter V is dedicated to monitoring the degradation of the isomers of propiconazole under controlled conditions and identifying the metabolites. From this study we hoped to extract information that would render valuable insight to the dosage and treatment frequency required to provide maximum against the DED pathogen, *Ophistoma ulmi*.

Chapter VI discusses the conclusions made from this research.

Chapter II

Review of Literature

Hawthorne and Majors have regarded sample preparation techniques as the most tedious, time consuming, and error prone step of an analytical procedure (14,15). Historically, sample preparation has not been a very important factor of method development. This explains why many agricultural and pharmaceutical companies are still employing dissolution and sample preparation procedures established over twenty years ago. The recognition of the poor performance of these traditional methods with respect to time of analysis, precision, and solvent usage has necessitated major development in this area.

Sample preparation is gradually coming to the forefront in the area of separation science. The goal of sample pretreatment is to make a complex sample suitable for chromatographic analysis. This is necessary for two main reasons: concentration of the target analyte and isolation of the analytes from the matrix. Both of these steps make for easier and better chromatographic performance.

With the growing number of analytical samples in environmental, polymer, pharmaceutical and agricultural applications emphasis is now being placed on developing fast dissolution techniques and clean-up procedures in order to increase sample throughput. This is particularly important when performing trace analysis. To be accepted in the analytical community the extraction and clean-up procedure must be applicable to a wide range of sample types and “non”- matrix dependent. Most of the samples in the aforementioned areas require that the target analyte be isolated from complex matrices before the initiation of chromatographic procedures. These matrices usually consist of non-volatiles and particulate matter that can have adverse or detrimental effects on a chromatographic system.

The aim of this work was to compare microwave-assisted extraction (MAE) for the isolation of systemic fungicides from woody plant material with the more popular extraction techniques. To date, several different techniques have been used to promote dissolution of polar compounds from agricultural matrices. These methods include Soxhlet Extraction, Thermal Desorption, and Supercritical Fluid Extraction.

Soxhlet Extraction

Wood is a highly complex substrate owing to its structure and the number and variety of components ranging from almost insoluble macromolecules, for example lignin and cellulose, to low molecular-weight aliphatic acids, sugars and alcohols (16). The usual procedure for the determination of wood volatiles and low molecular weight components is to extract with organic solvents and then analyze the extract by gas chromatography.

Soxhlet extraction has been the traditional method used for the extraction of pesticides and similar compounds from wood. When carried out for an adequate amount of time (usually > 12 hours) using a mixture of polar and nonpolar solvents it is possible to achieve an exhaustive extraction using this technique. Despite the additional need to concentrate the sample by reducing the amount of solvent, soxhlet extraction has been demonstrated to yield quantitative recoveries for most organic pesticides from agricultural matrices (17).

Soxhlet extraction involves solid-liquid contact for removal of one or several compounds from a solid by dissolution into a refluxing liquid phase. In a conventional soxhlet device the solid matrix is placed in a cavity that is gradually filled with the extracting liquid phase by condensation of vapors from a distillation flask. When the liquid reaches a preset level, a siphon pulls the contents of the cavity back into the distillation flask, thus carrying the extracted analytes into the bulk liquid (18). This procedure is repeated until virtually complete extraction is achieved (Fig.9).

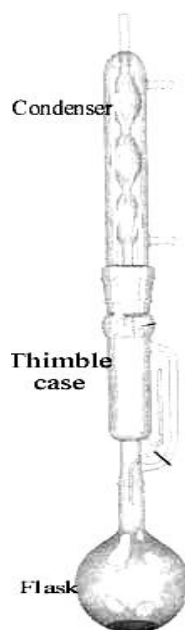

Figure 9: Schematic of Soxhlet Extraction Apparatus (19)

There are several advantages of Soxhlet extraction. The most important is that the sample is repeatedly brought into contact with fresh portions of the solvent. This procedure prevents the possibility of the solvent becoming saturated with extractable material and enhances the removal of the analyte from the matrix. Moreover, the temperature of the system is close to the boiling point of the solvent (20). This excess energy in the form of heat helps to increase the extraction kinetics of the system. Compared to supercritical fluid extraction and microwave-assisted extraction this increase in desorption kinetics is modest because the temperature of the solvent in the extraction cavity is lower than its boiling point.

The simplicity and well-documented applicability of Soxhlet has been contributing factors in its popularity. The glassware is relatively inexpensive; usually less than \$200 (19). The only physical property of the solvent that must be considered is the target analytes solubility. Moreover, the selectivity of the extraction can easily be manipulated by altering the polarity of the solvent.

Soxhlet extraction has several disadvantages, including: it requires several hours or days to perform; sample is diluted in large volumes of solvent, and due to the heating of the distillation flask losses due to thermal degradation and volatilization have been observed (20).

Gutierrez et al. (1998) reported the use of Soxhlet extraction to isolate lipophilic material from wood and pitch deposits to achieve an exhaustive extraction. Their reported extraction time was 6 hours (21). Likewise, Garcia-Ayuso et al. (1998) reported 8 hours to extract alkanes and PAHs from soil (17). The main reason that Soxhlet extractions require so much time is that the sample is not agitated. Agitating the sample can significantly accelerate desorption and/or dissolution of molecules bound to the matrix and reduce the extraction time. Another aspect of Soxhlet that contributes to the long extraction time is the fact that the sample is compacted into a narrow cellulose thimble. The position of the sample could mean that some of the matrix sites are not readily accessible to the solvent. This can lead to incomplete extractions. One way to avoid this phenomenon is to allow the extraction to reflux until cavities are formed within the matrix, which renders those hard to reach sites accessible to the solvent.

The typical solvent volumes when employing Soxhlet extraction range from 50 to 250 mL. Therefore, ultra-pure solvents must be used. This is particularly important when extracting trace level organic compounds because impurities in the solvent can interfere with the chromatographic analysis (22). Due to the large volumes of solvents used Soxhlet extraction produces dilute sample extracts, which must then be concentrated before analysis. Sample concentration reduces daily sample throughput and contributes to poor recovery because significant amounts of the target analytes can be “lost” during the concentration step.

Because heat is constantly applied to the bulk solution this may cause degradation of thermally labile compounds. To avoid sample degradation from occurring one can simply lower the heat applied to the distillation flask, but this may have adverse effects on the recovery. Another problem arising from the heat applied to the distillation flask is sample losses. This particularly true for volatile compounds.

Despite the literature which displays good recoveries using soxhlet extraction for a broad range of compounds; the long extraction time reduces sample throughput and make Soxhlet extraction an unattractive technique when a large number of samples must be analyzed.

Thermal Desorption (TD)

Though liquid extraction techniques were the traditional ways for isolating organic compounds from agricultural matrices, the increase in demand for these types of extractions required that a technique with a higher sample throughput be sought. Using thermal extraction techniques many organic compounds can be liberated from the sample matrix in a matter of minutes.

Part of the popularity of thermal desorption resides in its applicability to a wide range of sample matrices and its simplicity. It significantly reduces the amount of sample preparation steps because isolation, derivatization, and separation are all performed simultaneously. A major benefit of thermal desorption directly coupled to GC (TD/GC) is enhanced sensitivity because all of the desorbable components are transferred to the chromatographic system. Historically there have been problems associated with the quantitative transfer of semi-volatile compounds to the GC because the sample transfer line was a long, heated metal tube, which frequently adsorbed polar compounds. Today improvements have been made in the instrumental development of desorption units; with the advent of the “short-path” units (Fig. 10). These units deliver the sample directly into the heated GC-inlet zone. Sample components must be cryofocused into narrow bands inside the column in order to obtain good resolution of sample components. More efficient transfer of semi-volatile extractables is observed with the short-path units because condensation of analytes on the transfer line is avoided.

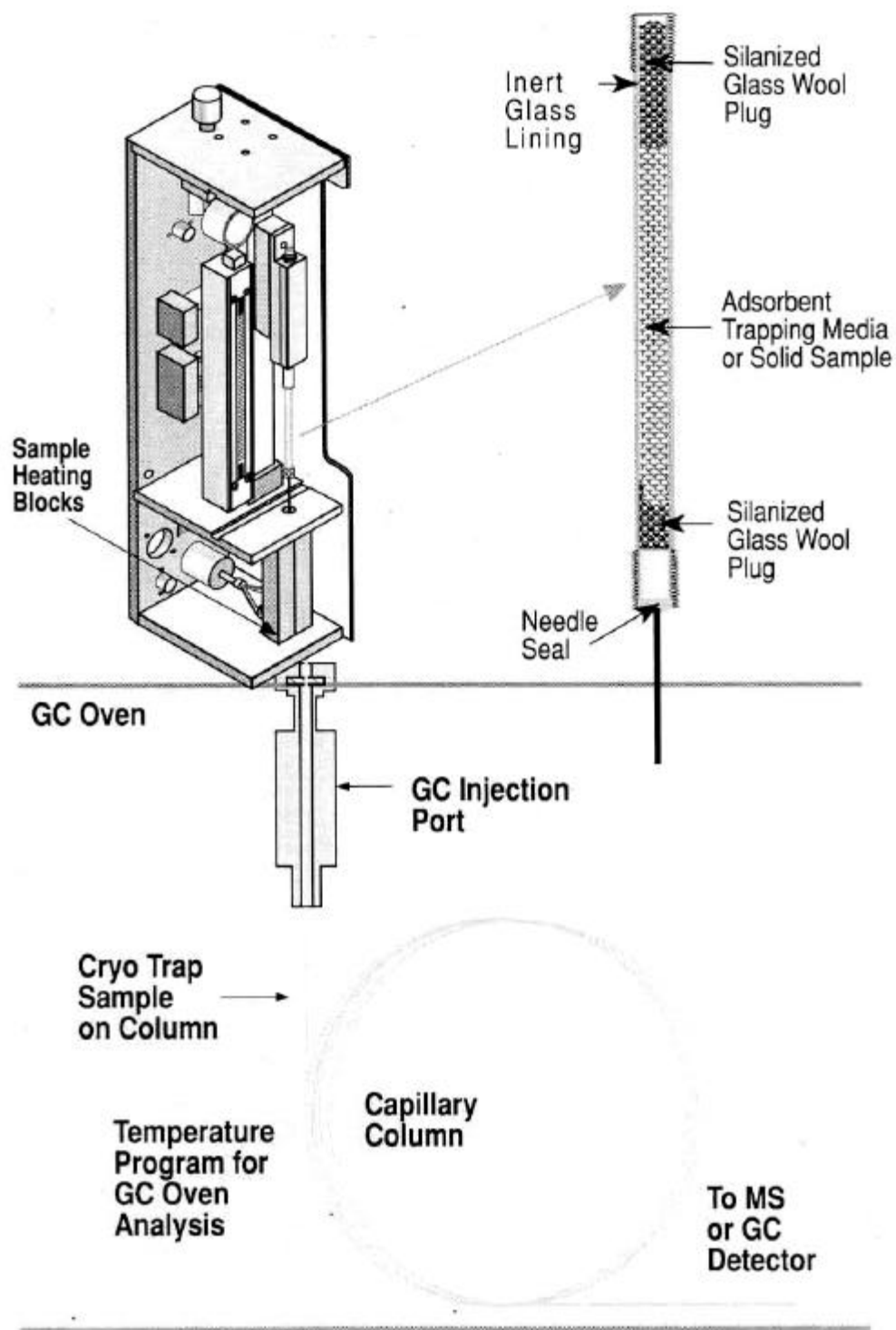

Figure 10: Schematic of Thermal Desorption Unit (23)

One type of thermal desorption system commonly used with agricultural samples is the furnace pyrolyzer. These types of thermal desorption instruments are characterized by the continuous application of energy. The sample to be analyzed is placed in a desorption cartridge, between two glass wool plugs (Inset of Figure 10). By heating the cartridge for selected time in a flow of inert gas, the volatile organic compounds are liberated from the sample. The power supplied to the pyrolysis heater is controlled by a thermocouple, which has been calibrated to give a known temperature (24). Variation in the supply voltage enables different heating rates and final temperatures to be selected. For the Dynatherm Desorption Unit (Kelton, Pennsylvania) used for this research the upper temperature limit is 350°C and the heating rate is 25°C/sec.

The desorbed compounds are then trapped on Tenax™ in a cold trap or directly loaded onto the head of the column. Using the trap is necessary when the matrix contains water. The presence of water can be detrimental to some GC stationary phases because they hydrolyze in the presence of water. In this case the analytes are first trapped onto an absorbent; then the water is removed from the system by purging or drying the trap with nitrogen gas. The trap is heated allowing rapid transfer of the analytes to the GC column.

When extracting trace level organics, secondary trapping is undesirable because sample loss during the drying step is unavoidable (24). Therefore, the recoveries are significantly lower than when this step is used. Most analysts choose the direct path method in which the sample is directly transferred to the head of the column.

Thermal desorption techniques are not selective; all volatile components will be volatilized. In complex samples many of those components can co-elute or interfere with the chromatographic analysis of the target analytes. This can make quantitation impossible and render the analysis useless.

The most significant disadvantage compared to Soxhlet is that thermal desorption is a matrix dependent technique. Thermal desorption seems to be well suited for “soft” tissue and porous matrices, such as, plant tissue and polymers. However, there is a dramatic decrease in performance for the extraction of non-porous matrices (25). Most samples are ground or minced in order to increase the surface area. The improvement in extractability that grinding the sample provides is clearly demonstrated by comparing data published by Harrington and Horn et al. (25, 26). In his study, Horn clearly

demonstrated that the recovery of pesticides from wood matrices is 45% higher if the samples are ground prior to analysis. Grinding the sample also helps to increase the diffusivity into and out of the matrix which, results in a major increase in extraction speed compared to bulky samples.

On-line thermal desorption/gas chromatography to analyze for pesticides and preservatives in wood was documented in the literature as early as 1979 and today continues to be a popular technique for isolating volatile components from wood matrices (25-28). Because desorption techniques lack selectivity they must be coupled with selected ion monitoring mass spectrometry to make the analysis more selective and to allow quantitation at trace levels. Most agricultural samples are extremely dirty and this can have negative effects on the operating quality of the mass spectrometer. This must be considered because instrumental maintenance contributes to the high capital cost associated with thermal desorption units.

The technical drawbacks of thermal desorption techniques are that the only ways to improve recovery of the target analyte are to increase the desorption temperature or to decrease the sample size. Both of those factors can have negative consequences. Increasing the desorption temperature may result in degradation of thermally unstable sample components. Decreasing the sample size may result in non-detectability of trace level compounds.

Applications of TD-GCMS are still limited due to the difficulties associated with the extraction of polar, high molecular weight, or thermal labile compounds. Unfortunately, many of the fungicides used in agricultural areas today fall into one of these categories. High temperatures may be required to break the intermolecular interactions between polar components and the matrix. A consequence of using high temperatures is that degradation of thermally unstable compounds may occur.

Priority pollutants in environmental samples are normally present at trace levels. This is the Achilles heel of thermal desorption techniques due to the fact that sample size is limited. The typical sample sizes used in desorption techniques range from a few mg to 1 gram. It is well documented in the literature, that the smaller the sample size the more efficient the matrix is heated, and the better recovery of the target analyte (29-31). Increasing the sample size of agricultural products is the most popular way to improve

the detectability of trace level components. Without the ability to concentrate the sample, the applicability of thermal desorption techniques to agricultural matrices is severely limited.

Supercritical Fluid Extraction (SFE)

The efficient and rapid extraction of pesticides from woody plant tissues is a formidable task; successful extractions using soxhlet and thermal desorption have been demonstrated (21-22, 25-26, respectively). Unfortunately, both the soxhlet extraction technique and thermal desorption fall short with respect to efficiency and time.

In the last 15 years supercritical fluid extraction (SFE) has become an established extraction method (15). Supercritical fluids possess several useful characteristics for the rapid extraction of organics from matrices. While they have solvent strengths that approach those of liquid solvents, they have lower viscosities and higher diffusion coefficients, which means mass transfer in supercritical fluids is faster and extraction time is reduced (15).

The dominant factors that govern the SFE of an analyte from a matrix are the solubility of the analyte in the supercritical fluid, the mass transfer kinetics of the analyte from the matrix to the solution phase, and interactions between the supercritical fluid and the matrix (32). Supercritical CO₂ is the most widely used solvent in SFE. Carbon dioxide is non-polar, non-toxic, and cheap. The selectivity of the solvent can be easily altered in order to increase the solubility of polar compounds by adding a modifier, such as methanol. Extraction efficiency is manipulated by changing extraction temperature, solvent density, matrix exposure time, and the composition of solvent. The solvating power of supercritical fluids increases with increasing density. This is accomplished by either lowering the temperature of the extraction or increasing the pressure (eq. 1). The instrumental and operating parameters are the same as for ASE (Fig. 11).

$$d = \frac{P(mV)}{RT} \text{ Eq. 1}$$

To date there are hundreds of applications published employing supercritical fluid extraction to isolate pesticides and natural products from agricultural matrices, such as wood. Meyer and Kleibohmer (33) used SFE to extract pentachlorophenol, a preservative from leather and wood. The samples were spiked and allowed to stand for 24 hours before they were extracted to facilitate matrix interactions. They claimed 98% recovery for the spiked wood samples and 90% recovery for the leather samples. They claimed the disparities in the recoveries are due to the type of matrix. Wood is very porous and CO₂ has little if any surface tension, so the fluid is easily able to diffuse into the wood and solubilize the target analyte and diffuse out of the matrix. By contrast, the pores in leather are much smaller and the matrix is “dry” which makes the surface harder for the CO₂ to penetrate. To achieve nearly 100% recovery they were required to carry out the extractions in both the static mode (10 minutes) and the dynamic mode (25 minutes). Therefore, the overall extraction time was 35 minutes.

Taylor et al. also used SFE to isolate natural products from kraft pulps (BKP) and chemithermomechanical pulps (CTMP) (34). To maximize their recovered extractable materials it was necessary to extract for 33 minutes. The worst scenario was reported by Raynor et al., for quantitative extraction using SFE of *Cedrela toona* a time of 60 minutes was required to overcome the “matrix effects” associated with extracting natural products (35). The aforementioned extractions took place between 40°C and 60°C. The extended time required is most likely related to the relatively low temperatures used in SFE.

Analyte trapping is another important aspect in SFE. Currently, there are two approaches in SFE analysis: the first, liquid solvent collection; the second, solid-phase trapping (32). Liquid-trapping has proven to be a reliable recovery technique for SFE because of the lower temperatures produced by Joule-Thompson cooling when the pressure on CO₂ is released. The result is enhanced trapping of volatiles and semi-volatile compounds. The second approach, solid phase trapping involves collection of the analytes from the gas phase onto solid sorbents. Usually, the trapped analytes are thermally desorbed from the sorbent material and then transported directly to the GC column. On-line coupling of SFE to GC increases analyte detectability because “all” of the extracted materials are measured because sample losses via other preparation steps are avoided.

Supercritical Fluid Extraction is without question a reasonable technique for the extraction of pesticides from woody plant material and other matrices. But the time required to complete the extractions are in most cases twice as long as microwave assisted extraction for comparable recovery data and in most analytical laboratories time is of the essence. Another drawback of SFE is the high capital cost (36).

Accelerated Solvent Extraction (ASE)

Accelerated Solvent Extraction (ASE) is an off-line extraction procedure that uses organic solvents under high pressures and high temperature in an automated system which consists of stainless steel extraction cells and electronically controlled heaters and pumps (37). The instrumentation is the same as a supercritical fluid extractor; the only difference is that SFE use CO₂ sometimes modified with organic solvents and ASE uses organic solvents (Fig.11). Carbon dioxide does not possess the solvent strength needed to efficiently extract polar analytes from complex matrices and the use of modifiers only moderately increases the solvent strength of CO₂. This is a limiting factor in the applicability of SFE. However, solvent strength is not a limitation when employing ASE.

Accelerated solvent extraction uses the same principles as microwave-assisted extraction but replaces microwave energy with oven heating. The solid sample is placed in a stain-steel vessel and brought to operating pressure by pumping solvent in the vessel. The vessel is heated to 50-200°C. When the extraction vessel achieves thermal equilibrium the pressure begins to build-up inside the extraction vessel. Once the pressure inside the extraction vessel reaches the pre-set value a pneumatic valve opens and allows the solvents in the extraction vessel to be transferred to the liquid trap. Fresh solvent is pumped into the extraction and the process begins again (37). So, the nature of the extraction procedure is both static and dynamic.

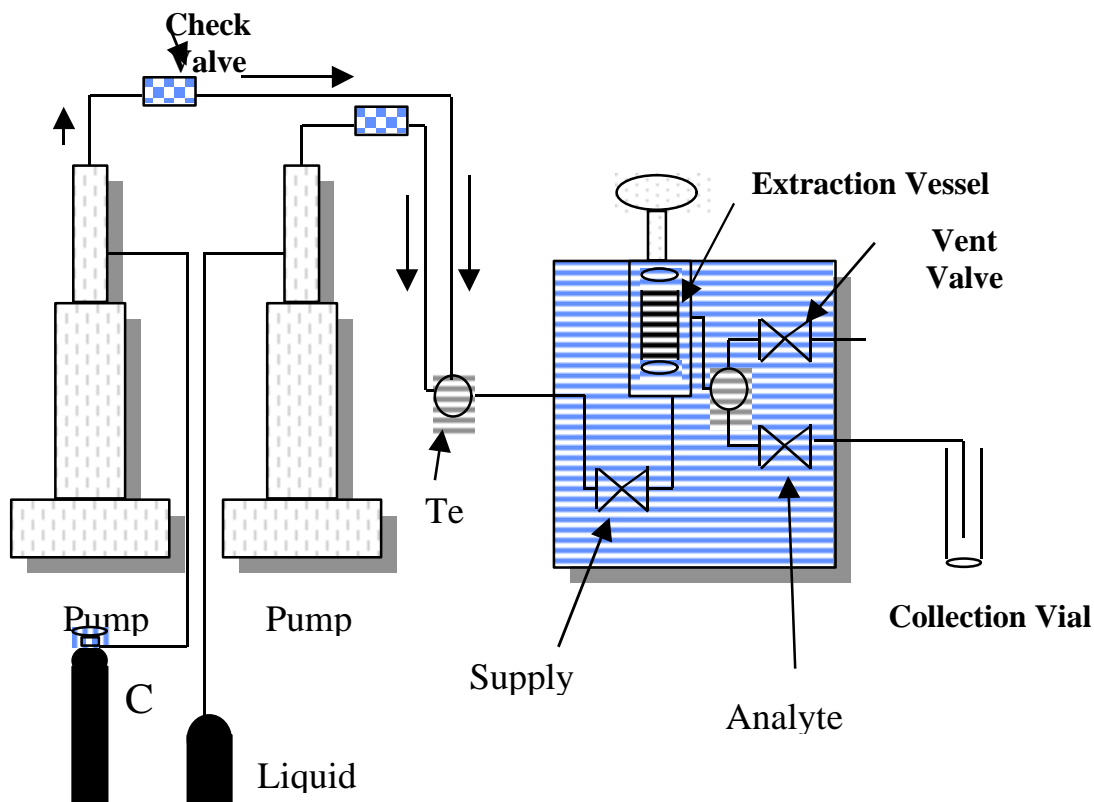

Figure 11: Schematic of Instrumental setup for ASE and SFE (37)

ASE provides faster extractions than conventional soxhlet extraction techniques, because of the accelerated desorption of analytes from the matrix and the more rapid kinetic processes for dissolution. In the case of most organic solvents, diffusion rates increase exponentially with temperature. This theory is based on the Arrhenius equation that illustrates that increasing the temperature of most organic solvents there is an increase in the desorption kinetics (Eq. 2) (38). Also, the Hildebrand solubility parameter, which states as the temperature of a liquid increases the viscosity decreases and the diffusivity increases (39). Both parameters are directly associated with the solvating power of the solvent. Due to the lowered viscosity and higher diffusivity of the solvent, mass transfer into the extraction solvent is faster. The higher temperatures also make it easier for the solvent to overcome intermolecular interactions of the analyte and matrix effects.

$$\log \frac{k_1}{k_2} = \frac{E_a}{2.30R} \left(\frac{1}{T_2} - \frac{1}{T_1} \right) \text{ Eq. 2}$$

ASE is not a selective extraction technique. Everything that is soluble in the solvent will be extracted from the matrix; this could possibly cause complex chromatographic analysis. But this small hindrance is easily overcome if the sample is analyzed by a mass spectrometer operating in the selected ion mode (SIM). Application notes have claimed that ASE is able to efficiently extract semi-volatile basic, neutral and acidic compounds, as well as pesticides, and other priority pollutants from difficult matrices such as soils, clay, and sludge (40). There is also a dramatic decrease in the amount of solvent required to perform an analysis. Soxhlet can require as much as 250 mL, whereas, ASE uses approximately 15- 25 mL per extraction vessel with comparable recoveries.

However, due to the high price (estimated at \$40,000) and limited experience associated with ASE it has not yet grown to or surpassed the popularity of Soxhlet, SFE or MAE. The main technical problem is analyte losses when the sample is being transferred to the collection trap. Generally, the extraction temperatures are between 100°C-140°C (much higher than SFE). During the transfer of the sample from the extraction vessel to the trap the pressure is gradually decreased to atmospheric conditions. During this time, Joule-Thompson cooling of the solvent occurs as the gaseous portions begin to condense back into the liquid phase, but this cooling is not enough to dissipate all of the heat. As a result, portions of the sample are lost while exiting the trap. Another disadvantage is there are no instruments currently on the market that can be directly coupled to a chromatographic system. The lack of an on-line system coupled with the high capital cost has resulted in limited acceptance of ASE.

Microwave-Assisted Extraction (MAE)

Microwave-Assisted Extraction was first employed to promote dissolution and digestion of metals found in soil and biological samples (41). The heating processes associated with MAE were believed to be “too intense” for organic molecules.

Microwave extraction was not used for extraction of organics until 1986 (41). In 1986, Salgo et al. published applications using a conventional microwave oven to enhance extraction of organic compounds from solid matrices such as soils, seeds, food, and feeds (42-43). Salgo et al. reported that MAE was more efficient than Soxhlet for polar compounds. In 1990, Terry and Onuska used microwave energy to extract organochlorine pesticides from sediment samples. They reported nearly 100% recovery for most compounds and no degradation as a result of exposure to microwave energy (44). Likewise, Pare and Belanger reported microwave as a sample preparation technique for extracting natural products from soft tissue plants (45). Microwave-Assisted Extraction has been applied extensively to the extraction of soils and soft tissue matrices. The focus of this research was to evaluate the feasibility of employing focused MAE for dissolution of propiconazole from a coarse matrix; wood.

Microwave energy is a non-ionizing form of electromagnetic radiation that causes molecular motion by migration of ions and rotation of dipoles, but does not normally cause changes in molecular structure (46). Microwave energy has a frequency range from 300 to 300,000 MHz. The most commonly used frequency for commercial microwave instruments is 2450 MHz, which corresponds to an energy output of 600- 700 Watts (46). The same wavelengths are used for radar and telecommunications transmission. Not to interfere with these uses, industrial and domestic microwave heaters are required to operate at either 2450 MHz or 900 MHz.

Two parameters define the dielectric properties of materials. The first, is ϵ' , the dielectric constant which, describes the polarizability of the molecule in an electric field. The dielectric loss factor; ϵ'' , measures the efficiency with which the absorbed microwave energy can be converted into heat. The ratio of the two terms is the dissipation factor, δ , (eq. 3).

$$d = \frac{\epsilon''}{\epsilon'} \text{ Eq. 3}$$

The physical parameters one must consider when choosing parameters for microwave extraction include: solubility, dielectric constant, and the dissipation factor

(δ). The first factor, is to choose a solvent in which the target analyte is soluble. Depending on the matrix and the interactions between the matrix and the analyte, one may need to choose a solvent with a high extracting power. Usually, the higher the dielectric constant the higher the degree of microwave absorption (Table 1). Water has the highest dielectric constant of common solvents. However, the dissipation factor is significantly lower than other solvents. So, the rate at which water absorbs microwave energy is higher than the rate at which the system can dissipate the heat. This phenomena accounts for the “superheating” effects which occur when water is present in the matrix. Localized superheating can have positive or negative effects, depending on the matrix. In some cases it can increase the diffusivity of the analyte in the matrix. In other cases, the intense heating can cause degradation of the analyte and/or “explosion” of the solvent.. To get maximum heat distributed through the matrix, it is best to choose a solvent that has a high dielectric constant as well as a high dissipation factor.

Table 1: Physical Constants for Commonly used Solvents (47).

Solvent	Dielectric (ϵ') F/m	Loss Factor (ϵ'') F/m	$\delta \times 10^4$
Water	80	12	1500
Acetone	20.7	11.5	5555
Methanol	23.9	15.2	6400
Ethanol	7	1.6	2286
Hexane	1.88	.00019	.10
Ethyl Acetate	6.02	3.2	5316

During MAE, a polar solvent with a high dielectric constant surrounds the matrix. Microwaves generated in a magnetron are applied in a pulsed fashion. The solvent molecules absorb the microwave energy and become polarized. When the microwave field is removed thermally induced disorder is restored (Fig. 13). This process heats the bulk solution and may cause localized superheating effects (only in matrices that contain water). Thermal equilibrium is eventually established within the system because the heat

is transferred from the bulk solution and the “pockets affected by superheating effects” via collisions so that the energy is distributed uniformly throughout the system.

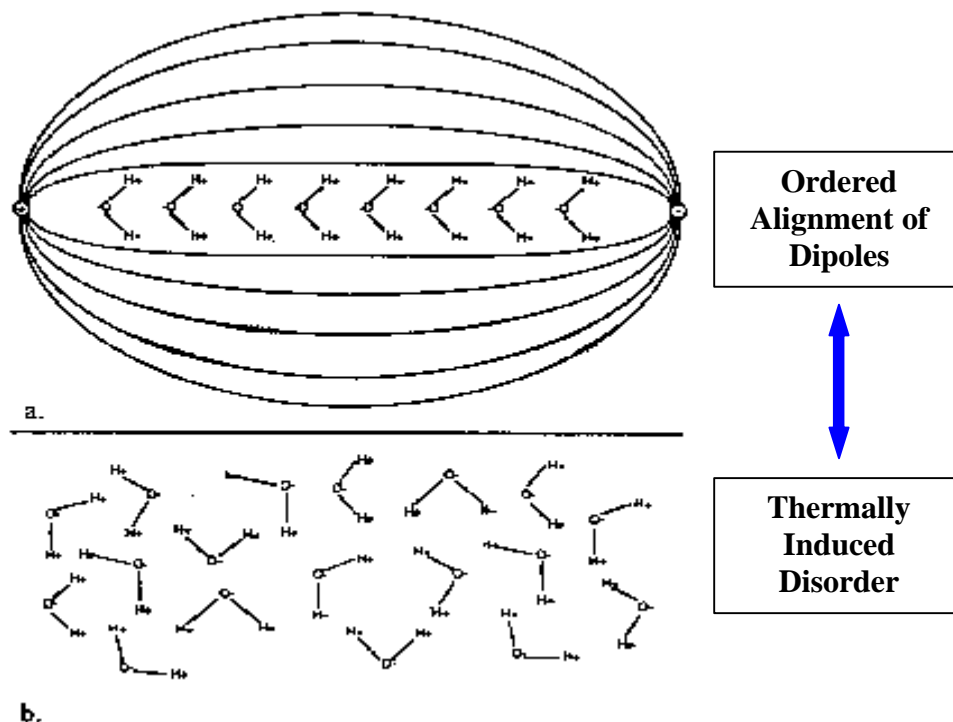

Figure 12: Effects of Microwaves on Water (46)

The final temperature of the extraction is proportional to the power (watts), time, and initial temperature; it is inversely proportional to the heat capacity of the solvent, and the mass of sample in grams (eq. 4) (48). The heat produced by the interaction of the microwaves with the solvent subsequently increases the diffusivity of the solvent and hopefully that of the analyte. The solvent is then able to diffuse into the matrix and extract the analytes; and then diffuse out of the matrix carry along the soluble components.

$$T_f = T_i + \frac{P_{abs}t}{KC_p m} - loss \quad \mathbf{Eq. 4}$$

Where, K is the conversion factor of calories to Joules, C_p is the heat capacity of the solvent, m represents the mass of the matrix, P_{abs} is the power absorbed, t is the time that the microwave field is applied, and T_i is the initial temperature.

The rate at which the solvent is heated depends on three factors: ionic conduction, viscosity, and dielectric loss factor (see Table 2). When using organic solvents the contribution of ionic conduction is negligible. However, most agricultural matrices contain small amounts of ionic species such as salts. The heating rate generally increases as the concentration of ions increase in the sample. A samples viscosity affects its ability to absorb microwave energy because it affects molecular rotation. When the molecules are “locked in position” as viscous molecules, molecular mobility is reduced thus making it difficult for the molecules to align with the microwave field (46). This will decrease the heat produced via dipole rotation. And of course considering the dissipation factor (δ), the higher this factor, the faster the heat will be transferred to the solvent.

Table 2: Heating Rate and Viscosity (47 and 49).

Solvent	Boiling Point (°C)	Viscosity (cP, 25°C)	Heating Rate (K/sec)
Acetone	56	0.30	2.20
Ethyl Acetate	77	0.43	1.78
Ethanol	78	0.69	1.20
Methanol	65	0.54	2.11
Water	100	0.89	1.01
Hexane	69	0.30	0.05

The dominate factors that govern the extraction of an analyte from a matrix by MAE are the solubility of the analyte in the solvent, the mass transfer kinetics of the analyte from the matrix to the solution phase, and the strength of analyte/matrix interactions. The first factor is obvious. For samples, with a homogenous composition and limited porosity, the rate of extraction is determined by the diffusion of the analyte to the surface of the matrix particle. Higher temperatures and swelling of the matrix increase the rate of diffusion and promote faster extraction kinetics. For wood samples

the rate of extraction is dependant on the diffusion of the analyte out of the pores, migration from one adsorption site to another, and displacement of the analyte molecules on adsorption sites by the solvent (50).

Currently, there are two types of microwave extractors that are commercially available: a closed-system and an open-vessel system. The main parameters to be considered when developing for the closed-systems are: solvent, temperature, pressure, power applied and the length of the extraction time. There are some safety concerns when employing closed-vessel extractions, for example, the possibility of explosion. Whereas, open systems are simple and usually safe, the optimization parameters are limited to: solvent, power applied and time. In both cases, the power and time are dependent on the type of matrix and the target analyte. There are advantages to both types of instruments.

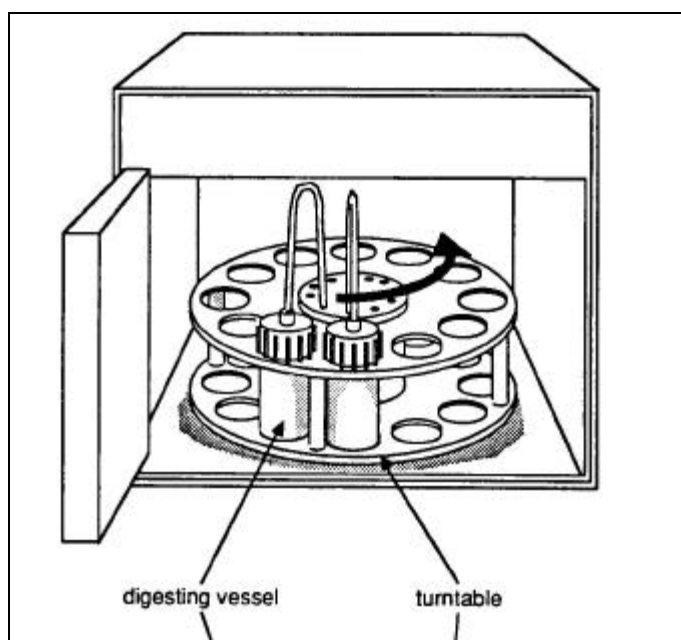

Figure 13: Schematic of a Closed-Vessel System (46)

The closed-vessel system operates under controlled pressure and temperature. The closed systems allows the temperature of the solvent to be raised above its boiling point. The maximum allowable temperature is 200°C and pressure maximum is 120 psi using the CEM model MES 1000 (Wilson, North Carolina) (Fig. 13). The technique

exploits the Arrhenius relationship of temperature to rate of desorption; increased mass transfer as a result of higher temperatures. Like SFE and ASE, the heating associated with MAE allows the solvent to rapidly overcome matrix effects and promotes faster desorption of the target analytes and other extractables.

The most impressive feature of closed-vessel MAE is that losses due to volatilization are minimized because the samples are allowed to cool before the vessels are opened. Also, most closed-vessel systems can extract up to 12 or 24 samples at the same time, which greatly increases sample throughput.

The major disadvantages of closed systems are that the time associated with closed vessel MAE and sample size seems to play a more critical role in extraction efficiency. With respect to sample size, the closed-system outputs the same amount of energy as the focused system but this energy is split between the 12-24 extraction vessels, which can reduce the heating rate of the solvent. Therefore, it is generally accepted that the sample size should be limited to 0.5- 1.0 gram. In some cases, this factor can be overcome by increasing the extraction time or power. This is an undesirable characteristic when one is trying to concentrate the target analyte by extracting larger volumes of sample. Another technical drawback is that it takes significant amounts of time for the samples to cool and depressurize.

Extractions using the open-system are performed at atmospheric pressures so the temperature inside the extraction vessel is normally within $\pm 5^{\circ}\text{C}$ of the solvent boiling point. The heating process is more efficient because all of the energy is focused on one sample instead of being split among several samples (48). When the temperature of the solvent approaches the boiling point, the solvent vaporizes, rises to a reflux condenser where it is condensed and returned to the extraction vessel.

The main features of the open-system are as follows: the ease of making reagent additions, efficient solvent/matrix heating, large sample capacity, and speed. With open systems derivatizing agents can be added while the extraction is taking place. This method will allow the target analytes to first be isolated and then reacted.

Percent recoveries of most analytes are not significantly affected by increases in the sample size. The sample capacity for most open commercial microwave systems can be as large as 10 grams (48). This is also directly related to the fact that most of the

microwave energy being produced in the magnetron is being directly focused to one sample cavity (Fig.14). Because of focused microwave energy compatibility with larger sample volumes it is generally accepted that the open vessel technique is well suited for ultra-trace analysis and sample concentration techniques (48). Another redeeming quality of the focused systems are that the analysis are generally twice as fast because of the more efficient heating and the shorter cooling time of the vessel.

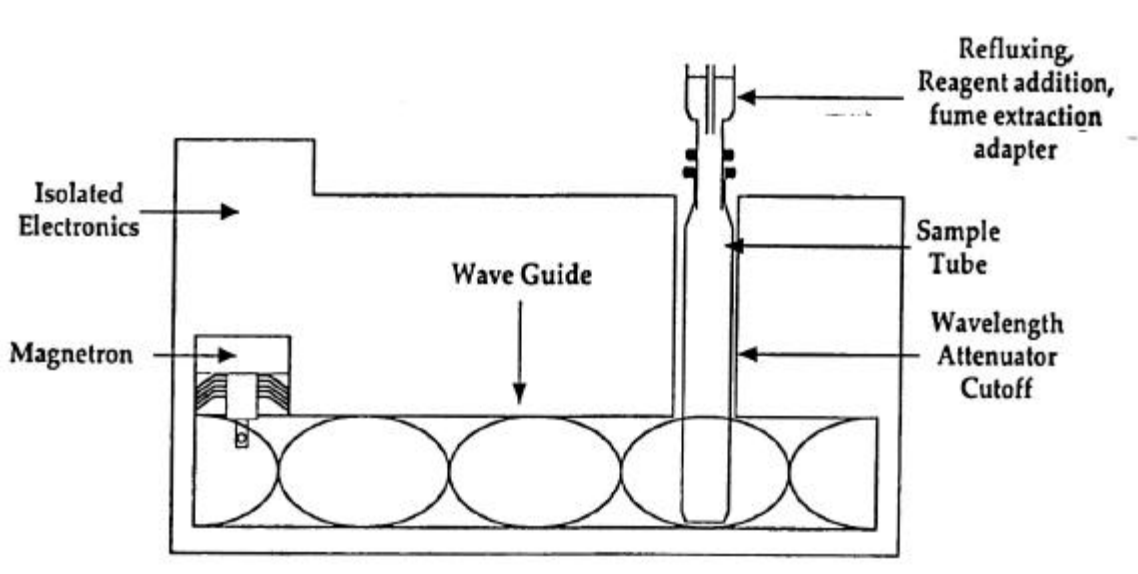

Figure 14: Schematic of a Focused Microwave System (48)

There are two main drawbacks to employing opens systems: losses due to volatilization have been noticed (48) and compared to the closed-vessel system sample throughput is reduced to a single sample per run. Lopez-Avila et al. noticed significant losses of volatile compounds such as benzene and lower molecular weight hydrocarbons when comparing open systems to closed systems (51).

Even though the principle of focused microwaves is efficient in terms of energy transfer it only allows for the use of one sample flask at a time. CEM Corporation (Wilson, North Carolina) has recently marketed a 2450 MHz four-vessel focused system; the drawback to this unit is that the energy is being split between the four vessels. There have not been any publications yet which compare the extraction efficiency of the open one vessel and the open four-vessel system.

Like ASE and SFE, microwave is a non-selective technique; all components soluble in the solvent will be extracted. This technique has been mostly used to isolate polar components from complex matrices, but MAE does have applicability to non-polar compounds as well. This is accomplished by using a non-polar solvent like hexane and adding weflon[®] (Milestone, PA) fibers that absorb the microwave energy and transfers the heat produced to the bulk solution.

Conclusions

According to the literature, MAE is a viable candidate for performing extractions of wood (41-48 and 50-51). The main advantages of Focused-MAE are shorter extraction times (typically 15 minutes), shorter cooling times (2 minutes) and less use of solvent (10 mL for MAE versus 250 mL for Soxhlet). The drastic reduction in extraction time results in a higher sample throughput without significant losses in analyte recovery. We hope to quantitatively illustrate these points in later chapters.

Chapter III

Quantitative Analysis of *Ulmus americana* Treated with Propiconazole: Optimization of MAE and Thermal Desorption

Introduction

Since its adaptation to organic compounds in 1986 by Salgo et al. (42), Microwave-Assisted Extraction (MAE) has been a developing extraction technique for the isolation of semi-volatile organic compounds from solid matrices. With Focused-MAE, the sample is placed in an open vessel and heated by microwave energy, using a microwave absorbing solvent. The hallmark feature of Focused-MAE is accelerated dissolution kinetics as a result of the relatively high extraction temperature (46).

An extensive survey of the literature revealed the diverse areas to which MAE has been applied; polymers, drugs, clothing/textiles, and agriculture. To date, MAE has been widely employed to extract priority pollutants from soils and crop plants (50-51). In 1996, Fish and Revesz reported the quantitative recovery of several thermally labile chlorinated pesticides, Endrin and DDT, with no degradation (52). Similarly, R.A Baumann et al. reported MAE as a sample preparation technique for isolating triazine fungicides from various soils and crop plants employing MAE followed by selective detection using the nitrogen-phosphorus detector (53). To date there is no published applications of MAE used to extract woody plant materials. This probably due to the complex nature of the sample and the time traditionally required for the extraction of woody material.

The purpose of this research is to evaluate the feasibility of employing Focused Microwave-Assisted Extraction (MAE) to rapidly isolate Propiconazole, [1-[2-(2,4 dichlorophenyl)-4-propyl-1,3-dioxolan-2-yl]methyl]-1 H-1,2,4-triazole, a systemic fungicide, marketed by Ciba-Geigy, Agricultural Division, (Greensboro, North Carolina) from *Ulmus americana*. Since propiconazole's first introduction in the literature by Urect et al. (54) its popularity has grown extensively primarily due to the fungicides broad range of activity.

Our interest in propiconazole resides in the fact that it is the active ingredient of Tilt[®], a broad-spectrum systemic foliar fungicide that is commonly used for the treatment of Dutch Elm Disease (DED). Elms are injected with massive amounts of Tilt[®] to prevent the DED pathogen from infecting the tree or as a curative agent for already infected trees. In this chapter, a MAE method was developed to extract propiconazole from wood, and compared with a Thermal Desorption method. The optimum MAE conditions were established for the quantitative recovery of propiconazole from spiked wood samples.

Experimental: Microwave-Assisted Extraction

Wood Preparation

Limbs of *Ulmus Americana* were collected from trees along Route 460 West (Blacksburg, VA, USA). The limbs were debarked and chopped into small pieces. The samples were then placed in an air tight and waterproof container. The debarked samples of untreated *Ulmus americana* were later ground to a size of less than 2 mm using a Wiley Mill (Wiley, Pittsburgh, PA). The processed wood samples were stored in the freezer until needed.

Spiking Procedure

The first objective was to determine if propiconazole could be quantitatively recovered from wood. Five grams of *Ulmus americana* was weighed in 100 mL borosilicate glass containers purchased from Supelco, Inc. (Bellefonte, PA). Extremely wet samples were allowed to air dry for maximum interaction of the propiconazole with the active sites. The samples were then spiked with 1 mL aliquots of 150, 100, 50, 25, 10, 5, and 1 ppm solutions of propiconazole dissolved in methanol. The spiking solutions and calibration curves were prepared by serial dilution of a 500 ppm stock solution of propiconazole. The propiconazole was purchased from Chem Service Inc. (West

Chester, PA) and the methanol from AlliedSignal, Burdick and Jackson (Muskegon, MI). The purity for both the methanol and propiconazole were stated to be higher than 96%.

The standard solutions were added slowly with an Eppendorf pipet also purchased from Supelco Inc. (Bellefonte, PA) covering the surface of the wood matrix to prevent interaction with the glass surface. The solvent was allowed to evaporate. The spiked wood matrix was allowed to equilibrate in darkness for 36-hours to allow matrix interaction (55).

Microwave Instrumentation

A Soxwave model 100 (2.45 GHz, maximum power 300W) microwave extractor from Prolabo (Fonetenay-sous-bois, France) was used. In contrast to the pressurized systems, in which the microwave energy is dispersed throughout the oven, the system works under atmospheric pressure, and the microwave energy is focused directly into a single vessel. Higher power density at the sample and thus better heating efficiency can be obtained. The Soxwave 100 allows the applied energy to vary from 5% to 100% (of 300 W) in increments of 5%.

Microwave-assisted extractions are carried out in a sample vessel made of Borosilicate glass. The volume in which the microwaves are focused is approximately 10 mL. A holder was made of teflon to keep the tube in place inside the cavity. The sample vessel was fitted with a reflux condenser.

Extraction Procedure

The spiked samples were quantitatively transferred to the sample vessel. The spiking containers were rinsed 5 times with 0.2 mL aliquots of the solvent to remove components leached to the glass. The samples were extracted with 10 mL of methanol. We also wanted to study the effects of pH on the extractability of the triazole fungicides. In some samples the pH was adjusted to about 8.5 with 1 mL of triethylamine. The triethylamine was purchased from Aldrich Chemical Company (Milwaukee, WI). The

solvent composition for the pH-adjusted samples was 9:1 (v/v) methanol and triethylamine.

Circulating cold water cooled the condenser for 30 minutes prior to starting the extractions. After adding the sample, the sample vessel and condenser was connected. The extractions were performed at 90W (30% power) and 120W (40% power) for times of 10 and 15 minutes. After extraction, the vessel was allowed to cool to room temperature before removing the reflux condenser. The supernatant was first filtered through GF/C 42.5 mm glass microfibre filters purchased from Fisher Scientific (Pittsburgh, PA) and was combined with the 2-5 mL of methanol used to rinse the container. The solvent was evaporated using nitrogen blowdown and rediluted to 1 mL using methanol. The extracts were all analyzed using GC/MS.

Analysis of Extracts

Analysis of the extracts was performed on a model HP5890 Series II gas chromatograph interfaced to a HP model 5971 mass spectrometer (MSD) and equipped with a HP model 5973 autoinjector. The gas chromatograph, mass spectrometer and autoinjector were all purchased from Hewlett-Packard (Palo Alto, CA).

The column used was a HP-5MS 30 m x .25 μm film thickness x .25 mm i.d.; fused silica open tubular column. The stationary phase is a 5% diphenyl and 95% dimethylpolysiloxane. This column is excellent for the separation of halogenated compounds. Hewlett-Packard (Palo Alto, CA) donated the column. A HP inverted cup liner was used in the injection port to prevent particulate matter from contaminating the column. The helium carrier gas velocity was 40 cm/sec.

The GC analysis was performed in the temperature program mode. The temperature program was slow to ensure that the propiconazole isomers were completely resolved from other sample components. In an effort to avoid sample carry over, the column temperature started at 190°C and then programmed to 300°C at 10°C/min, where it was held for 5 minutes.

The electron energy on the MSD was set at 70 eV and the multiplier voltage was varied to attain good sensitivity. The temperature of the transfer line was set at 300°C; the average temperature of the ion source was 160°C. The analyses were performed in the

selected ion mode. The ions of propiconazole scanned were 259, 173, and 69 m/z. The instrument was tuned daily with PFTBA introduced via the calibration gas valve. Unknown compounds and propiconazole was confirmed using the Wiley Library of the HP software package.

The injector was set in the split mode. Because we were analyzing trace quantities the split ratio was set to 10:1; this was mainly to prevent other extractables from contaminating the mass spectrometer source. The temperature of the injector was set at 280°C. The injection volume was 1 µL and because the samples were somewhat viscous the sample syringe pumping delay was set for 3 seconds.

Quantitation

The data generated was quantitated using the external standard calibration method. Calibration curves were constructed by injecting at least five standards made by serial dilution of a stock solution in methanol. Only correlation coefficients of $r \geq .98$ were accepted. No data was reported beyond the range of the calibration methodology.

Triplicate extractions were performed for each concentration to illustrate the repeatability of the extraction technique. The standard deviation and % relative standard deviations were calculated.

Limit of Detection and Quantitation

A five-point calibration was performed to establish the GC/MS linear range, limit of detection (eq. 5), and the limit of quantitation (eq. 6) (56). The limit of detection (LOD) and quantitation (LOQ) were calculated using the Foley and Dorsey technique for determining the limit of detection (56). The limit of detection refers to the smallest signal above the background noise that an instrument can reliably detect. The limit of quantitation is the lowest concentration of an analyte that a method can reliably detect in a sample. The limit of quantitation needs to be determined when it is necessary not only to detect the presence of an analyte but also to determine the amount present with a reasonable statistical certainty. The LOD and LOQ were determined for propiconazole in

the scan and the selected-ion mode. The calculated values are listed in Table 4. Using the equations listed below, the LOD and LOQ were calculated at the 95% and 99% confidence intervals, respectively.

$$\text{LOD} = \frac{3\text{Sd}_n}{m} \text{ Eq. 5}$$

$$\text{LOQ} = \frac{10\text{Sd}_n}{m} \text{ Eq. 6}$$

Where, Sd_n represents the standard deviation of the instrumental noise and m is the slope of the calibration curve.

Table 3: Limit of Detection and Limit of Quantitation

MODE	LOD (mg/kg)	LOQ (mg/kg)
Scan	.05	0.5
SIM	.01	0.1

ANOVA

Analysis of variance is used in this research to evaluate whether the means of the data sets were statistically different. The ANOVA analyses were calculated in Excel (Windows 98) version. All ANOVA analyses were performed at the 95 % confidence level.

Microwave-Assisted Extraction: Optimization of Recovery

Effects of Microwaves on Wood Xylem Cells

Scanning electron micrographs were taken from control (non-treated) (Fig. 15) and microwave-extracted wood xylem cells (Fig. 16). The xylem vessels are hollow and cylindrical in structure; they carry water and pesticide treatments throughout the tree. They contain a significant amount of water and in the presence of microwave energy can undergo “superheating” because the bulk solutions are not able to dissipate the heat as rapidly as it is generated. So, the microwaves interact with the bulk solution and the free water molecules; causing localized super-heating. The result is a sudden non-uniform rise in temperature with more pronounced effects where the water is in larger proportions. For wood, the vascular systems are the prime target because they are the major carriers of water. The temperature increases rapidly to the boiling point of water and sometimes higher. The result is a dramatic expansion in the volume of the system. The walls of the vascular system can not accommodate the high internal pressures that are created as a result of the microwave energy. They rupture allowing the contents to flow freely toward the relatively cool surrounding solvent that solubilizes them rapidly (Fig.16).

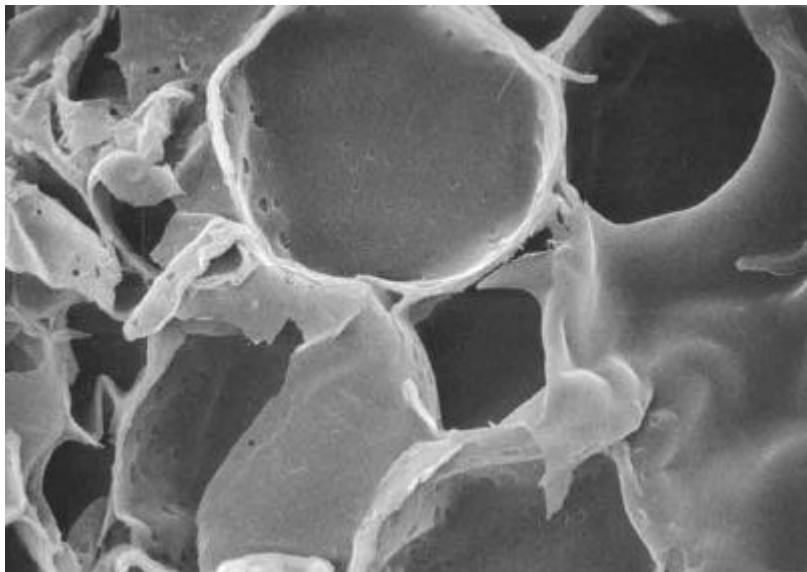

Figure 15: Transverse View of Unexposed Xylem Cell

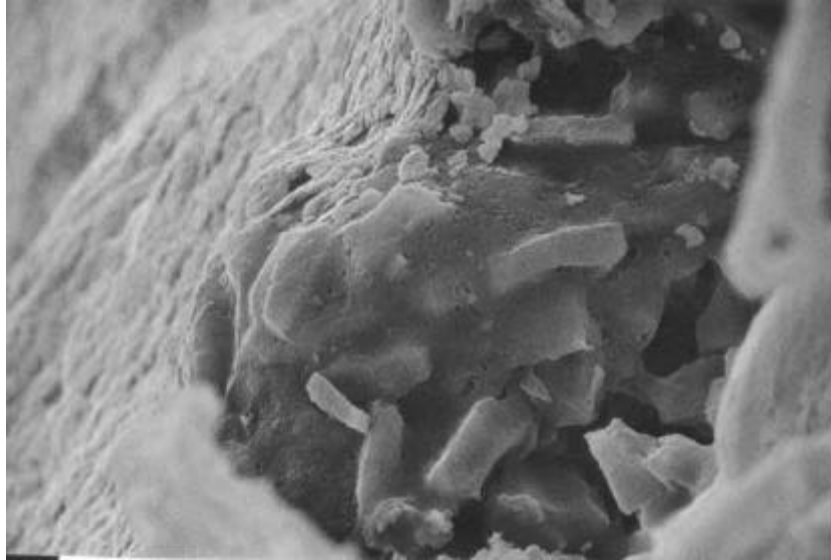

Figure 16: Xylem Cell exposed to 90 W of MAE irradiation for 15 minutes

Figure 17 is an electron micrograph of the xylem pits. Figure 18 is an electron micrograph that illustrates good penetration of microwaves or the heat generated by MAE to internal structures inside the xylem vessels. This was assessed by the amount of damage to the cells.

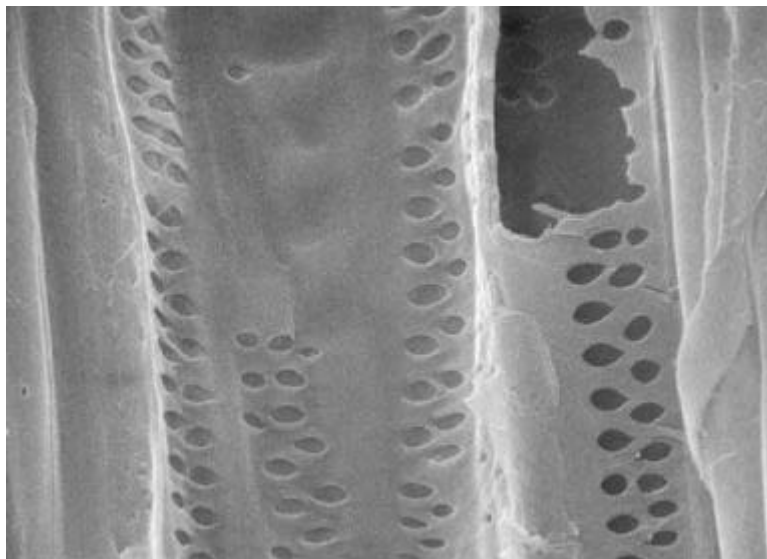

Figure 17: Non-treated Xylem Pits

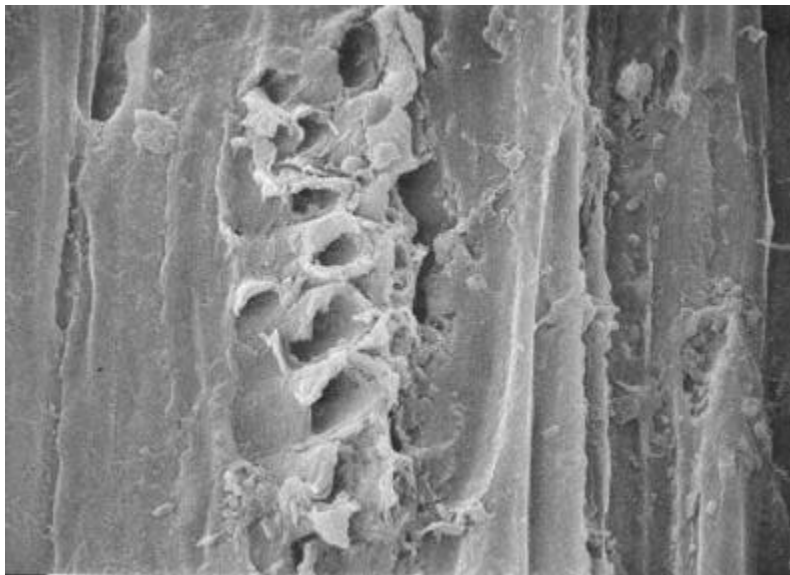

Figure 18: Pits of Xylem Vessels that have been exposed to 90W of MAE for 15 minutes

GC-MS Analysis

During the optimization of the microwave extraction conditions, all the extracts were analyzed by GC-MS. Figure 19 gives the total ion chromatogram of the propiconazole isomers. Propiconazole has two chiral centers located at the 2- and 4-positions of the central dioxolane ring and therefore propiconazole exist as four stereoisomers, two enantiomer pairs, one cis and one trans. The enantiomer pairs inseparable; they co-elute. However, the diastereoisomers (cis and trans) can be easily separated (Fig. 19). The isomers produce identical mass spectrums. The trans isomer will be used to generate quantitative data.

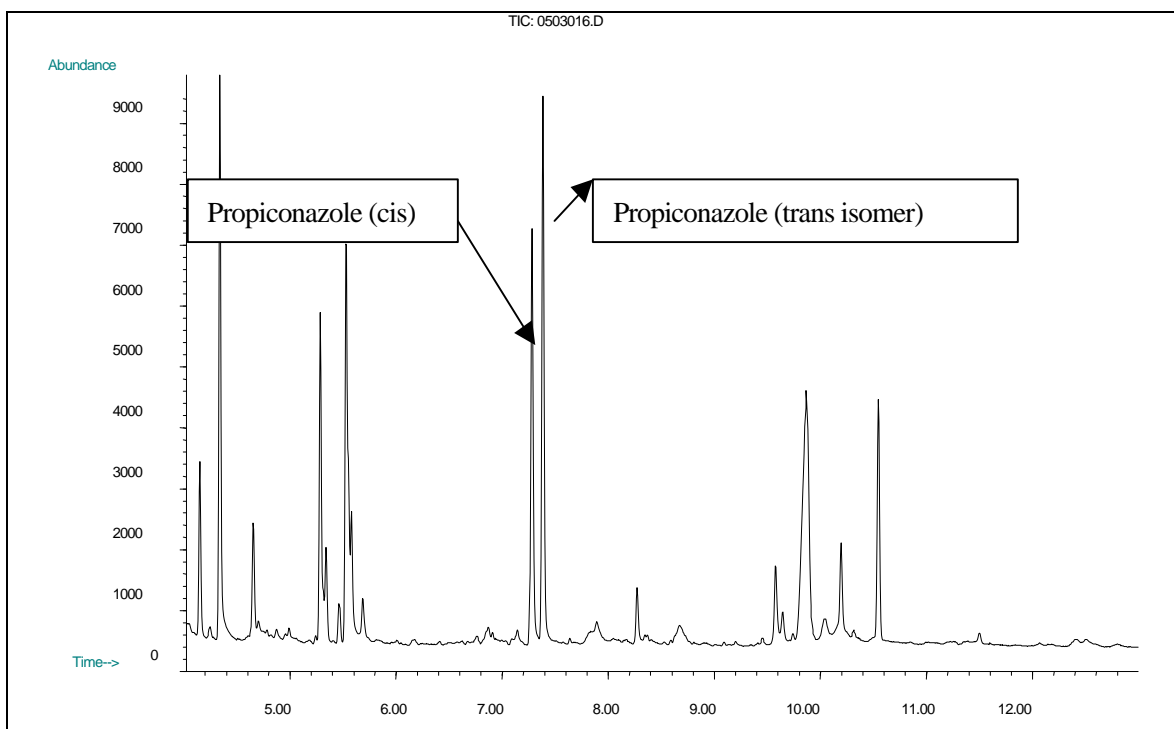

Figure 19: GC/MS of *Ulmus americana* Treated with Propiconazole

The other extractable compounds include fatty acid methyl esters, phenols (which is a degradation product of lignin), neutral sugars, ketones, and alcohols. Most of the aforementioned compounds require derivatization before they are thermally stable and the activity of the compound minimized. Otherwise, the molecules degrade in the injection port or irreversibly adsorb to the column.

Solvent Type

The first step in optimizing a MAE method is choosing the appropriate solvent. The most important physical characteristic is that the target analyte must be soluble in the extraction medium. The selectivity is limited to those compounds that are soluble in the solvent. With MAE, the solvent used must also have a high dielectric constant and a high dissipation factor. The dielectric constant describes the solvent's ability to absorb

microwave energy and the dissipation factor (δ) describes the molecule's ability to eliminate the absorbed microwave energy as heat (46).

This section compares the extraction efficiency for three commonly used solvents in MAE. Propiconazole exhibited sufficient solubility in all three solvents. The solvents were methanol, acetone, and ethyl acetate. Polar solvents, such as acetone, methanol or ethyl acetate are most commonly used to extract pesticide residues from agricultural samples; these solvents are miscible with water, which means they can penetrate the matrix effectively. All three solvents are heated at nearly the same rate and the dissipation factors are very similar. Methanol has a slightly higher dissipation rate than either acetone or ethyl acetate, which means methanol should be heated more efficiently. This should result in faster mass transfer kinetics and better recoveries when using methanol as a solvent. Figure 20 compares the % recoveries for the three solvents.

Figure 20, clearly indicates that the recoveries at trace levels are lower when using acetone and ethyl acetate as the extracting solvents. This can be due to two factors: incomplete extractions and/or losses due to volatilization. In the case of ethyl acetate we are inclined to believe that the poor recoveries are because the interactions between propiconazole and the wood matrix are not being completely broken. Ethyl acetate has the both the lowest heating rate and the lowest dissipation factor therefore it should not be as efficient a solvent as methanol and acetone.

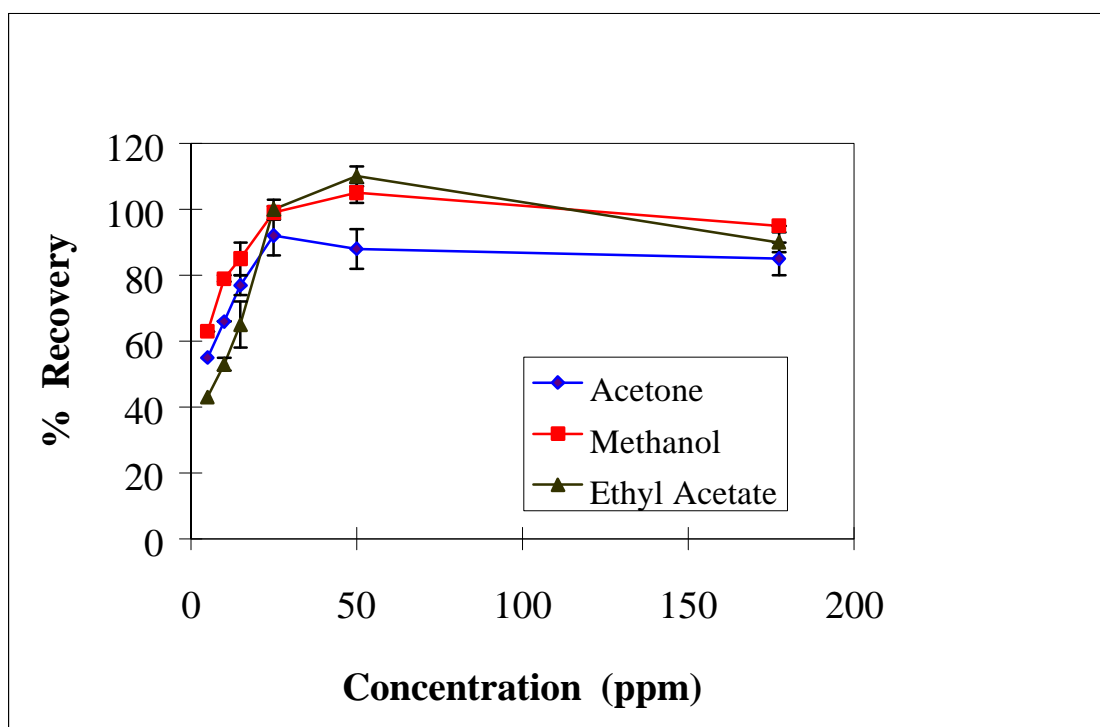

Figure 20: The Effects of Solvent on Extraction Efficiency of Propiconazole from *Ulmus americana* employing MAE at a Power of 90 Watts for 15 minutes

Extraction Time

Time is a critical factor in any extraction procedure. Many of the variables that will determine whether or not an extraction technique will be exhaustive are governed by time. For example, temperature equilibrium between the matrix and the solvent, and diffusion of internally bound analytes to the surface of the matrix where they may solvated and removed by the solvent are important time related factors.

Figure 21, illustrates that the recovery of propiconazole from wood is significantly higher when the extraction is allowed to proceed for longer times. At a power of 90 Watts, and varying the extraction time between 10 and 15 minutes, at 10 minutes 66% (n=3) of the propiconazole was recovered with an RSD of 3.7 % whereas, an extraction time of 15 minutes 94% (N=3) of propiconazole was recovered with a RSD of 8.2 %. ANOVA analyses of the time variable indicates that there is a statistical difference between extraction times of 10 and 15 minutes; F_{cal} 35.28 and $F_{critical}$ 7.7. The longer the extraction time the more quantitatively propiconazole is recovered from the wood matrix.

The solvation process for MAE occurs in several stages. First, a cavity must be created in the solvent to accommodate the solute (57). The solute is then placed in the cavity and allowed to interact with the solvent molecules; eventually forming strong intermolecular interaction with the solvent molecules. The solute is then solvated.

As the temperature of most organic solvent increase their solvating power also increases. Efficient extraction then becomes dependent on a dynamic equilibrium process occurring between solvent molecules and the matrix. Adequate time and convection should enable the bulk solution to uniformly distribute the “energy” throughout the system.

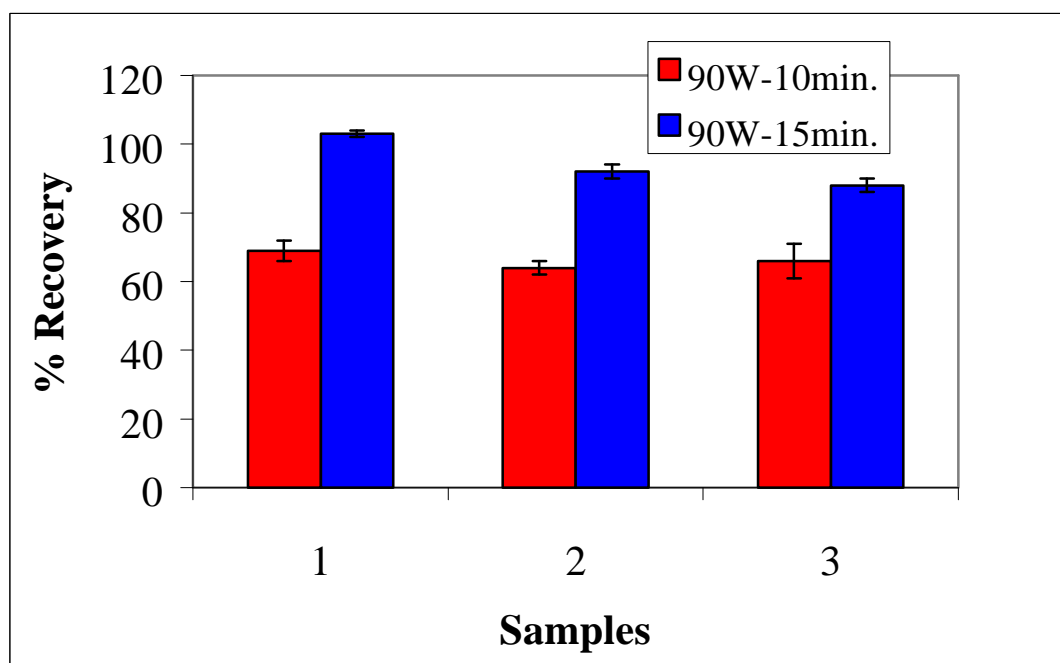

Figure 21: Influence of Time on Recovery of Propiconazole. The samples were irradiated at a power of 90W for 10 and 15 minutes; MeOH was used as the solvent.

Power

When employing focused MAE, microwave energy is directly focused to one sample. This results in the solvent being more efficiently heated. Equation 4 (pg. 26) relates power to the extraction temperature. The higher the power the more heat generated up to the solvent boiling point in focused systems. Because the energy is directly focused, excessive heating can occur and possibly degrade the target analyte. Consequently, the lowest power that produces an exhaustive extraction should be used as a preventative measure.

To date there have been no reports of sample degradation in the literature but one should be mindful that sample degradation or reaction occur if the power is too high.

The effects of power are not as profound as the effects of time. Increasing the power from 90W to 120 W for 10 minutes does significantly improve the recoveries of propiconazole, F_{cal} 34.6 and $F_{critical}$ 7.7 (Fig. 22). However the propiconazole is not totally removed from the wood matrix. At a power of 120 W, 76% of the propiconazole bound to the wood matrix was removed whereas at a power of 90 W, only 66 % was recovered. The data cited was the average of three runs (n=3). Simply increasing the temperature only results in a 10% increase in the amount of propiconazole recovered; under these conditions the extractions are not yet exhaustive.

It was concluded that inputting a larger amount of heat into the system increases the extraction kinetics, but the time of the extraction is still the critical factor (Fig. 23). Figure 23, illustrates that at a power of 120 W and an extraction time of 15 minutes the results are 100% with a RSD of 10 %. This confirms our assumption that power plays an important role in the extraction of propiconazole from the wood matrix but adequate time must be allowed to overcome the matrix interactions.

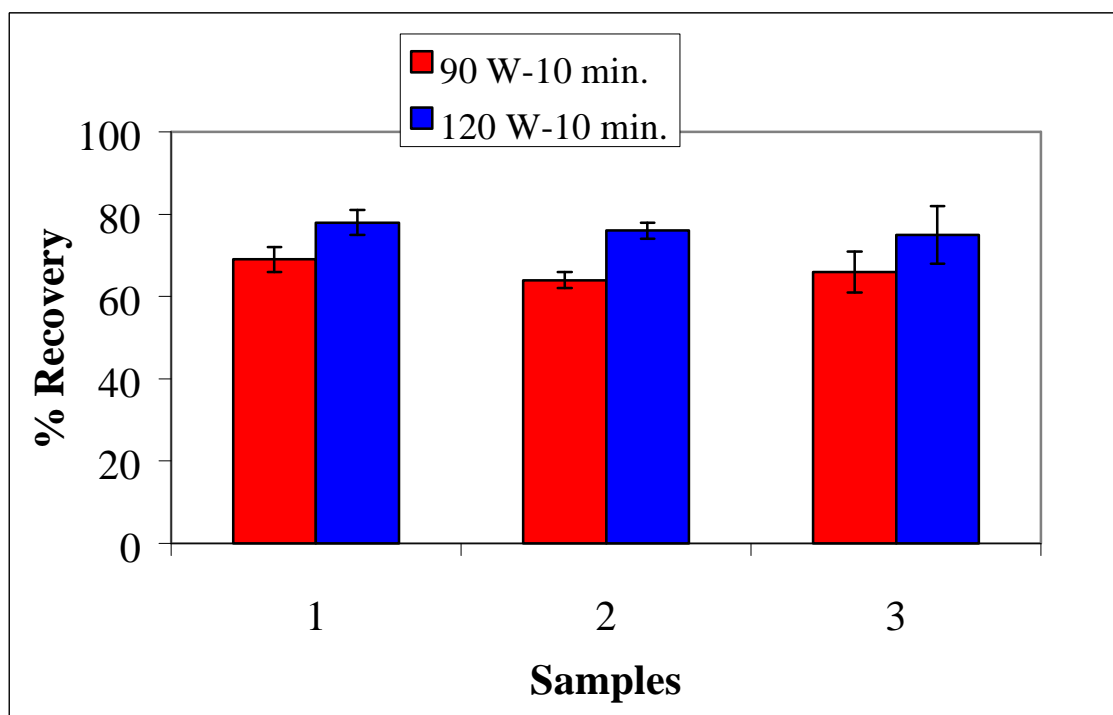

Figure 22: The Effects of Power on % Recovery of Propiconazole from *Ulmus americana*. Methanol was used as the solvent

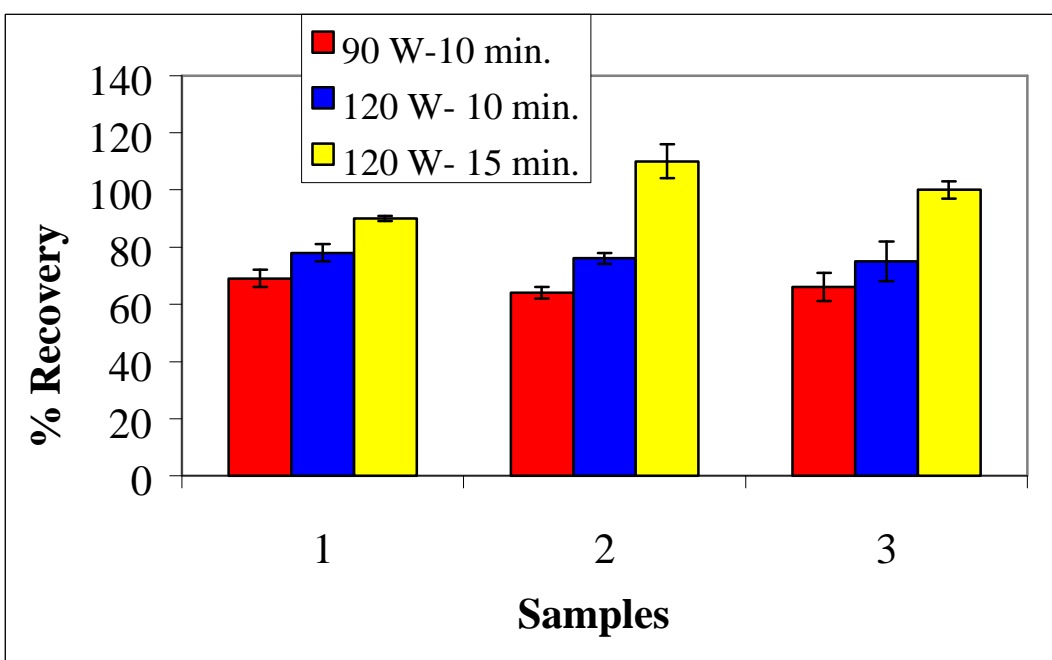

Figure 23: Effects of Power and Time on Recovery of Propiconazole Spiked on *Ulmus americana*; MeOH was used as the solvent.

The extractions were nearly exhaustive when the solvent was given adequate time to interact with the wood matrix. It is imperative that degradation of the fungicide is avoided, therefore, we performed extractions of spiked samples at a power of 90 W for 15 minutes. We compared the data sets statistically to 120 W for 15 minutes using a ANOVA analysis. At a power of 90 W and 120 W, 94% with a RSD of 8% and 100 % with a RSD 10%, of the spiked amount propiconazole was recovered, respectively. The ANOVA of the power variable indicates that there is not statistical difference in the extraction of 90 W for 15 minutes and 120 W for 15 minutes; $F_{\text{cal}} .017$ and $F_{\text{critical}} 7.7$ (Fig. 24). The data clearly reveals that establishing a temperature equilibrium in the system helps to overcome matrix effects and has a more significant role in improving the recovery of propiconazole than just simply increasing the temperature.

The optimized MAE extraction conditions were a power of 90 watts for 15 minutes. At these conditions the recoveries were nearly 100% with good precision. The lowest power setting was chosen to avoid possible degradation of propiconazole.

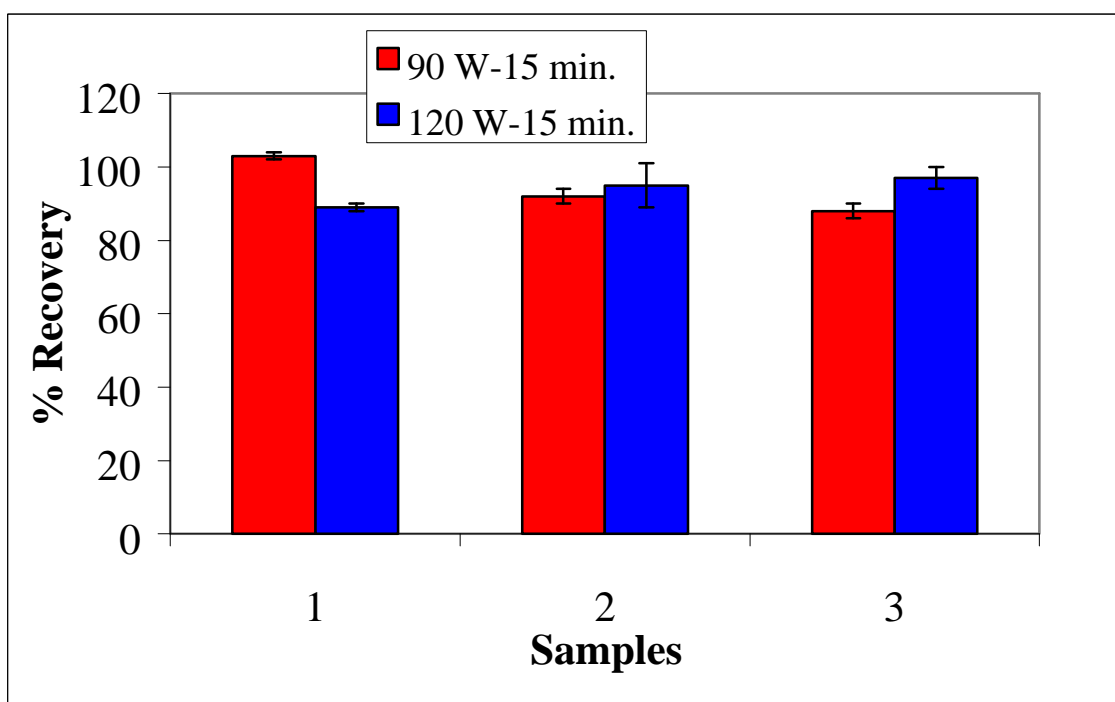

Fig. 24: Comparison of Samples Extracted at Powers of 120 W and 90 W for 15 minutes; MeOH was used as the solvent.

Role of pH on Extractability

Propiconazole has characteristics of a base due to the nitrogen atoms, which comprise the triazole moiety. Tadeo and Lafuente developed a technique for analyzing post harvest fungicides (thiabendazole and propiconazole) in citrus fruits. They reported increased recoveries of propiconazole when the extracting solvent was pH adjusted to 8.0 due to the basic character of the molecule (58). For detailed method development the role of pH on extractability of propiconazole from wood was investigated (57).

Solute-solvent interactions are dependent on the natures of the solute and solvent. The interactions are weakest when both are non-polar, they become stronger as the polarity of the molecules increases, and it is strongest when one of the interactions are caused by hydrogen bonds between the solute and matrix. In agricultural and environmental samples there are several constituents that can hydrogen bond with polar fungicides, such as, propiconazole. Therefore it is necessary to find or modify a solvent so that it may form strong and specific interactions with the solute to be extracted. For many organic compounds, with acidic or basic character the solubility has been known to increase by altering the pH to suppress ionization or protonation of the target analyte

Our objective was to thoroughly study the extractability of propiconazole from the wood matrix. We extracted three replicate samples of treated wood with neutral methanol solvent and methanol that had been pH adjusted to 8.5 with triethylamine (Fig. 25).

The data indicates that pH is not an important factor in obtaining good recoveries of propiconazole from *Ulmus americana*. The recovery with methanol is 94% (n= 3) with a RSD of 6% and the recoveries of the solvent pH adjusted to 8.5 with triethylamine is 92% (n= 3) with a RSD of 8.2%. There is no difference in the recovery of propiconazole in the non-pH and pH adjusted samples. This conclusion was confirmed by statistically comparing the recoveries using an ANOVA analysis. The null hypothesis states that there is no statistical difference in the recoveries of samples extracted at a pH 7.0 and 8.5 because $F_{cal} (.126) < F_{critical} (7.7)$.

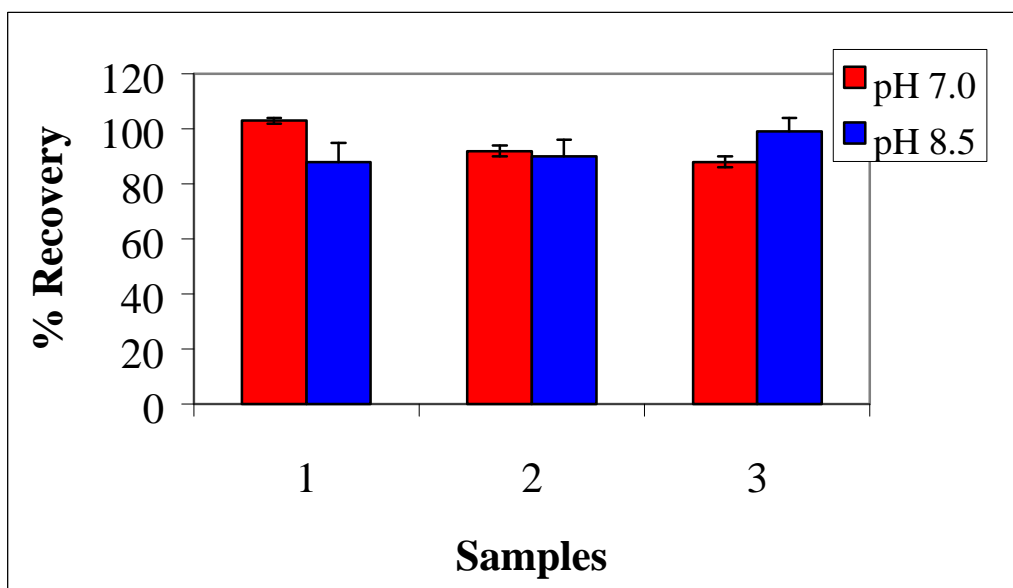

Fig 25: The Effect of pH on % Recoveries of Propiconazole from spiked samples of *Ulmus americana*. The MAE extraction performed with a power of 90W for 15minutes with MeOH as the solvent.

Correction Factors

Concentration of analytes, sample matrix, and time of storage influence recovery of organic compounds. After the optimum extraction conditions were established the recoveries of varying concentrations of propiconazole was determined (Fig. 26). The data illustrates that the amount of propiconazole recovered is concentration dependent. At lower concentrations the systematic error inherent in the method is more apparent.

These losses may be attributed to two factors: incomplete extraction of propiconazole from the wood matrix or losses during the sample preparation procedure. To eliminate the possibility of incomplete extraction the samples were extracted twice; no propiconazole was recovered in the second extraction. Also, when a standard of propiconazole (25 ppm) was carried through the complete sample preparation procedure the recovery was 87%. It was concluded that sample losses during the sample preparation technique are responsible for the lower recoveries at trace levels. To correct for these systematic losses of the sample occurring at lower concentrations, correction factors (Eq. 7) will be multiplied to the experimental data (59). All experimental data will be reported as “recovery-corrected.”

$$CF = \frac{C_{\text{exp}} * 100}{R_{\text{average}}} \quad \text{Eq. 7}$$

Where, C_{exp} is the calculated concentration and R_{average} is the average amount of propiconazole recovered from the spiked samples.

Table 4: Average Recoveries and Correction Factors

Concentration (ppm)	Average Recovery (%)	Correction Factors
1	40	2.5
5	49	2.1
10	73	1.4
15	77	1.3
25	85	1.2
50	95	1.1
75	96	no CF
100	102	no CF
175	99	no CF

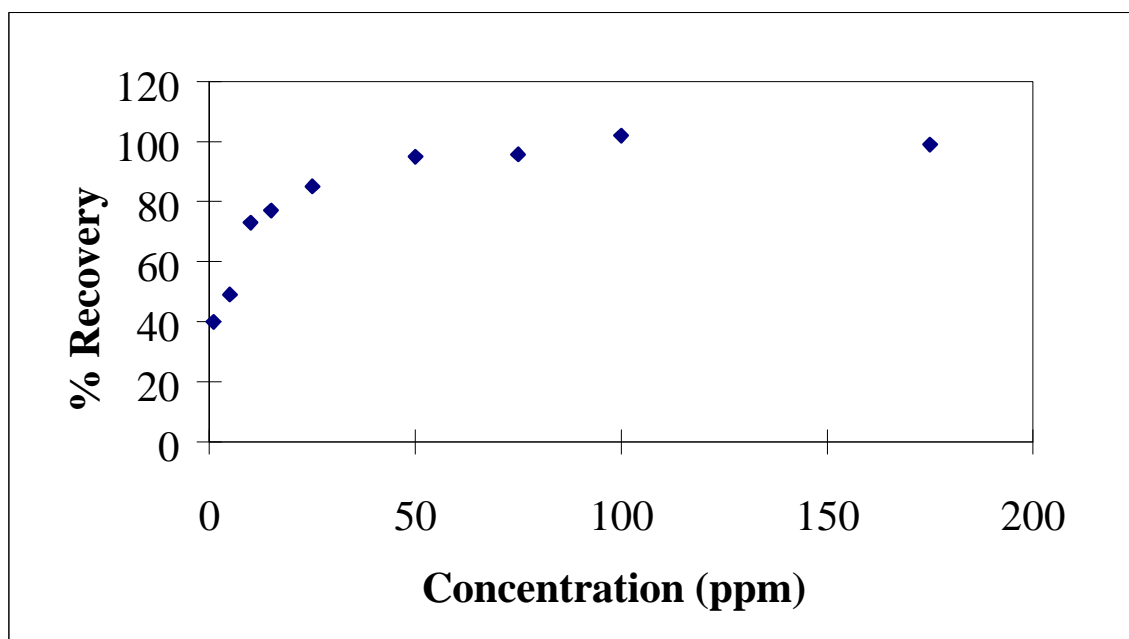

Figure 26: Recovery of Propiconazole from *Ulmus americana* at MAE Irradiation of 90 W for 15 minutes the solvent was Methanol.

Thermal Desorption Parameters

The samples were desorbed using the Dynatherm Thermal Desorption unit (Dynatherm, Inc., Kelton, PA). The thermal desorption unit was directly interfaced to a HP model 5890 Series II gas chromatograph (GC) with a HP model 5971 mass spectrometer detector (MSD). The Dynatherm desorption unit did not have cold trapping capabilities. The desorbed molecules were transferred directly to the GC column. The column used was an HP-5MS 30 m x .25 μ m film thickness x .25 i.d. which was threaded through a 1-meter heated sleeve (sample transfer line). The temperature setting for the valve was 220°C and the transfer line temperature was kept at the maximum; 200°C.

Spiking Procedure

The wood samples (0.5 grams) were weighed into desorption cartridges of 4 mm internal diameter and 4 inches in length (Supelco). The wood sample was loosely packed to allow the carrier gas to flow through the cartridge without creating backpressure. Glass wool plugs were placed around the sample to prevent wood particles from plugging the carrier gas lines. The samples were then spiked with 1 μ L of 150, 100, 50, 25, 10, 5, 1 ppm solutions of propiconazole dissolved in methanol using a 1-10 μ L Eppendorf pipet. The solvent was allowed to evaporate. The spiked matrix was allowed to equilibrate for 36-hours to allow matrix interactions.

Extraction Procedure

The cartridges were loaded into the Dynatherm heating chamber. The samples were heated ballistically and held for 2 minutes at 280°C and 300°C. The extractable material was transferred directly to the chromatographic column.

The extractions using thermal desorption are non-selective; all components in the matrix with adequate vapor pressure at the desorption temperature will be removed. The chromatograms generated of environmental samples are extremely complex due to the large number of sample components (Fig. 27). Due to the large number of desorbed components a slower temperature program rate was necessary to completely resolve the

target analytes from other extracted material. The increased noise levels had an adverse effect on the detection limit of the mass spectrometer. In spite of these problems, efforts were made to obtain quantitative results by using a selective detector, in this case, a mass spectrometer. All thermal desorption analyses were performed in the selected ion mode to enhance sensitivity and eliminate noise. Ions characteristic of propiconazole were scanned; 259, 173, and 69 m/z.

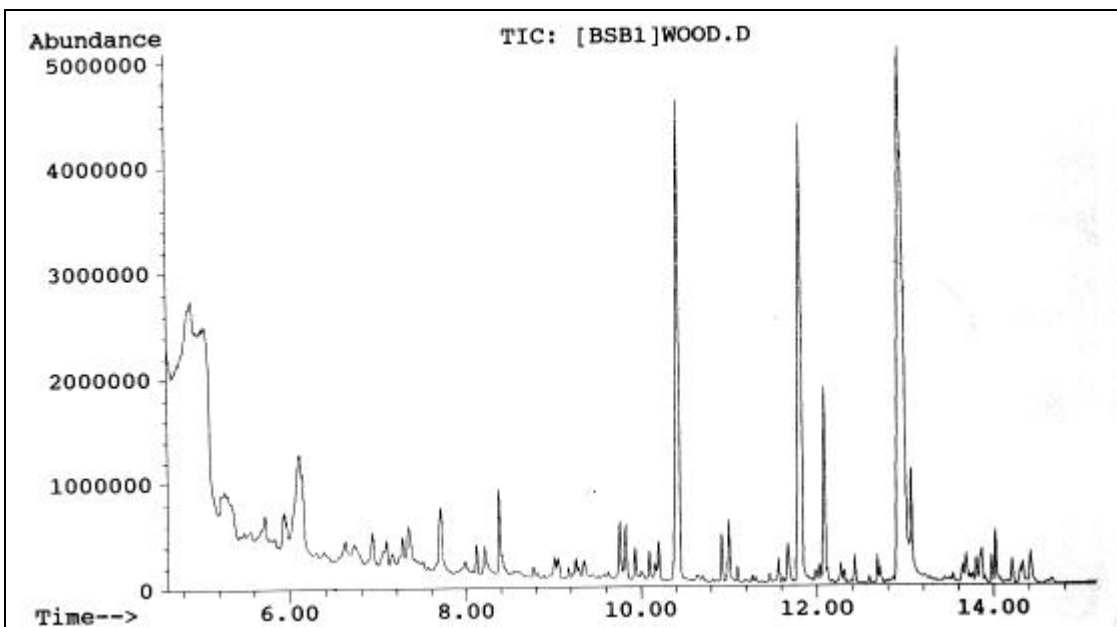

Figure 27: Pyrogram of *Ulmus americana* Treated with Propiconazole (13.9 minutes)

The major drawback of thermal desorption directly interfaced to mass spectrometers is when analyzing dirty samples, such as wood it is necessary to clean the source once a week. Cleaning the source is time consuming, however, without keeping the source clean sensitivity of the instrument is lowered.

Results and Discussion

Due to the simplicity of thermal desorption it is one of the most popular extraction techniques employed by analytical chemists. Unlike MAE and other liquid extraction techniques, thermal desorption is a relatively simple technique it does not require expensive instrumentation. The only important variable in producing good recoveries of target analyte is the desorption temperature.

For maximum performance, the appropriate desorption temperature must be experimentally determined for each sample. If incorrect desorption temperatures are selected the consequences are thermal degradation if the temperatures are too high or incomplete extraction if the temperature is too low.

This section discusses the extractability of propiconazole from *Ulmus americana* employing thermal desorption. Thermal desorption has been used extensively in the characterization of “soft tissue” plant material (27-29). Our purpose was to determine if thermal desorption performed as well as MAE for the extraction of woody plant material.

The wood samples were spiked with 50 ppm of propiconazole and were thermally desorbed at two different temperatures, 280°C and 300°C for a time of 5 minutes. The data generated from this study indicates that thermal desorption is not a good extraction technique for isolating polar materials from wood. The average recovery at 280°C was 23% (n= 3) with a RSD of 54% and at 300°C the recovery was slightly higher at 45% (n= 3) with a RSD of 22% (Fig.28). There is a marked improvement for the desorption temperature of 300°C, but neither desorption temperature yielded quantitative results. Figure 27 also illustrates that the precision is poor.

Thermal desorption has many desirable characteristics: the extractions are fast, the detection limits are good, and no additional sample concentration steps are needed. The poor performances of thermal desorption for our work is probably due to the fact that not enough time is allowed for the heating process so the whole system does not come to a thermal equilibrium because the penetration depth of heat is low. As a result, the propiconazole that is internally bound is not removed. This phenomenon most likely accounts for the poor recovery and the lack of reproducibility in the thermal desorption of wood.

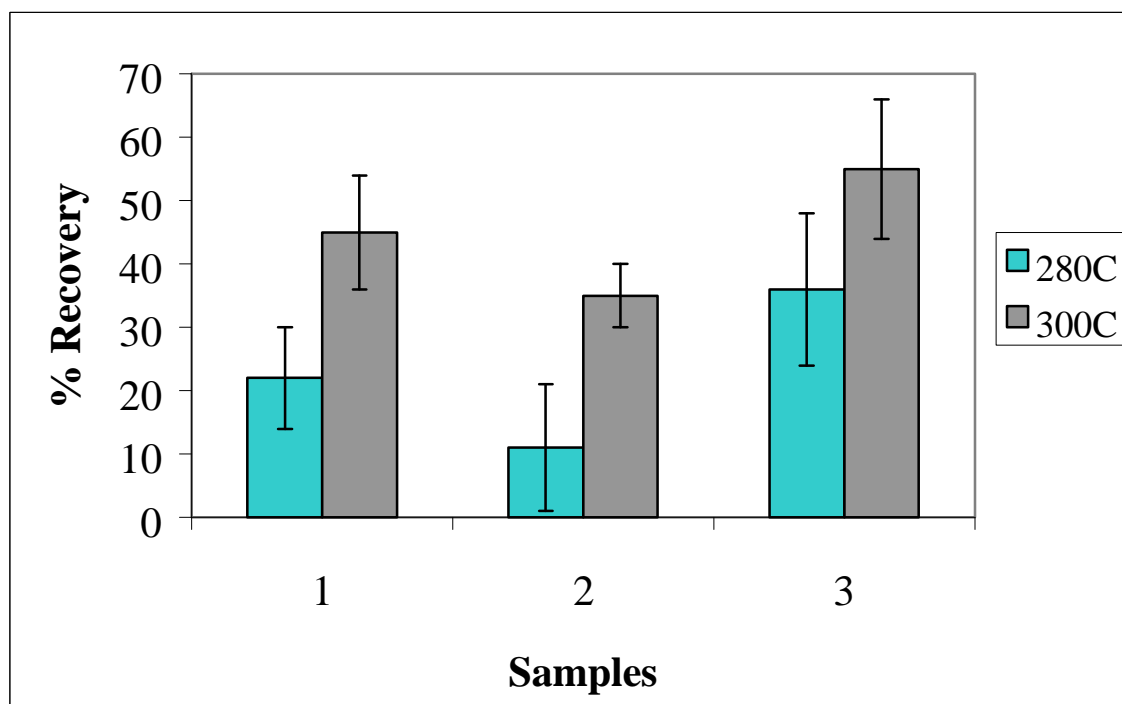

Figure 28: Comparison of Desorption Temperatures for the Extraction of Propiconazole from *Ulmus americana*

Conclusions

Microwave-Assisted Extraction out performs thermal desorption (Fig. 29); recoveries are higher and precision is better. Under optimized conditions Microwave-Assisted Extraction quantitatively isolates propiconazole from wood matrices; nearly 100% recovery with RSDs $\leq 10\%$ at concentrations levels greater than 25 ppm. The recoveries employing thermal desorption are consistently low, $< 60\%$ with RSDs in the range of 22%-54%.

The optimized conditions for MAE are 90 W of power for an extraction time of 15 minutes. The method described is simple, fast, and reproducible. MAE provides a faster extraction because of the higher temperatures used and requires less solvent. Post extraction cleanup is minimal.

This method will be used to monitor residual levels of Propiconazole, [1-[2-(2,4 dichlorophenyl)-4-propyl-1,3-dioxolan-2-yl]methyl]-1 H-1,2,4-triazole in trees that have been injected or infused with the pesticide.

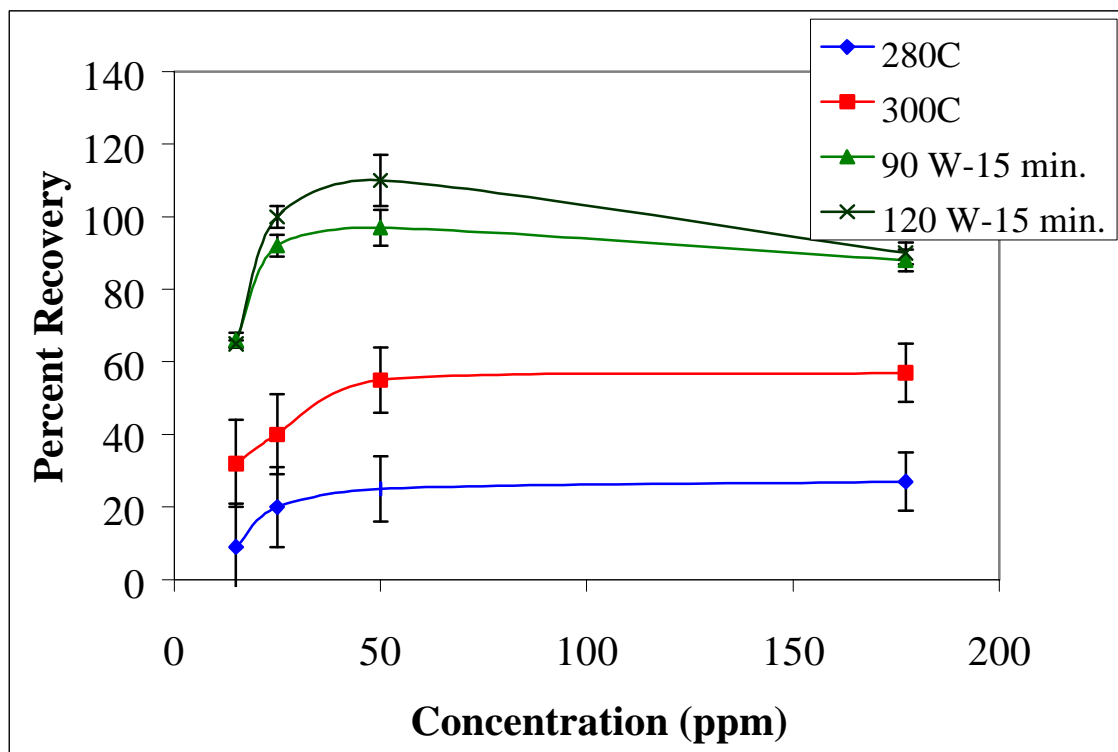

Figure 29: Comparison of Thermal Desorption and Microwave-Assisted Extraction for the Isolation of Propiconazole from Woody Plant Tissue

Chapter IV

Residual Fate Studies of Propiconazole

Introduction

Dutch elm disease (DED), a vascular wilt disease of elms caused by the fungus *Ophiostoma ulmi*, has destroyed a large population of one of North America's most important shade trees. There have been several procedures used to manage DED. These include reducing the number of insect vectors, eliminating breeding sites, removing infected trees (sanitation), and severing root graft between diseased and healthy trees (1-5, 60). These techniques have proven to be useful for reducing losses in large populations, but they are impractical for protecting individual trees or small groups at high risk of infection (61).

Localized epidemics of DED have caused enormous losses of valuable elms. The high value of elms as shade and ornamental trees and the subsequent impact elms have on property values continue to stimulate research on control alternatives such as intravascular injection of fungicides (62). Systemic fungicides are introduced into the root system or directly into the trunk. The earliest attempts to control DED in American elms with systemic chemicals took place at the Connecticut Agriculture Experiment Station (63). They achieved moderate success at prolonging the lives of elms infected with DED, but no curative results were noted. More promising fungicides were needed.

Within the last 10 years triazole fungicides have become important in controlling a wide range of economically important plant diseases (61). These compounds inhibit ergosterol biosynthesis in fungi, are very fungitoxic at low concentrations and are systemic in woody plant materials (64). For the past 15 years, thiabendazole has been used primarily in the treatment of DED (60). However, the higher minimal inhibitory concentration of thiabendazole required to eradicate *O. ulmi* has made it an optional choice. Stipes et al.(1986) noted that propiconazole has a lower minimal inhibitory concentration of 1 ppb; almost immediately the use of the traditional fungicides were

abandoned and propiconazole became the new focus of the attention. In addition, propiconazole is more “tree friendly,” that is, less phytotoxic.

These injections are applied by injecting the product directly into holes drilled into the xylem off the root flares of the tree. The number of holes, hole depth and the position of holes around the trunk determine the distribution of the compound. The number of injection sites is determined by the tree diameter at breast height.

Propiconazole moves upward in the xylem and has little to no downward movement in the phloem. To be effective, any systemic fungicide must be delivered uniformly to susceptible tissues in adequate concentrations. Currently, there are two types of injection techniques: macro-infusion (Fig. 30) and micro-injection (Fig. 31). Macro-Infusion delivers more volume (concentrate diluted with water), while micro-injectors deliver the same quantity of fungicide but in the most concentrated form. Micro-injector units containing the desired chemical is placed inside the holes and pressurized which allows the material to enter the root flare. Uptake of the fungicide using the micro-injection technique is slow because the formulation is viscous and must be diluted by the in the sap stream.

During the injection process the product forms a vertical column in the xylem cell. The larger the volume of fungicide injected per hole, the broader the distribution of active ingredient in the sapwood (65). The due to the high water solubility of propiconazole, it precipitates out in the xylem cells almost immediately following injection as the solution is diluted into the water in the xylem (66). However, due to its polar nature an unknown amount of the analyte adsorbs to the xylem cell walls and must be removed by the sap ascent. This removal process may continue over several hours to days.

Fluid movement in the xylem almost totally ceases during periods of severe drought, after defoliation from insects or disease, or during dormant periods when leaves are absent.



Figure 30: Macro-Infusion of *Ulmus americana* with Alamo Fungicide on the Campus of Virginia Polytechnic Institute and State University



Figure 31: Micro-Injection of a tree in Venice, Italy

To determine the relative strength of the chemical activity and uniformity of chemical distribution in the crown of the treated trees, branch samples from each tree are bioassayed. The traditional method for detecting the presence of fungicides in wood is using a zone of inhibition study (Fig. 32). In this study small chips of wood from injected trees are plated on agar which has been treated with *O. ulmi*; restricted growth of *O. ulmi* positively identifies the presence of the fungicides. This bioassay test failed to detect propiconazole in wood treated with the fungicide. Our assumption concerning this matter is that the propiconazole stays localized inside the xylem vessels and does not diffuse into the new wood. Therefore, a non-traditional means of detecting propiconazole in elm wood was established in Chapter III.

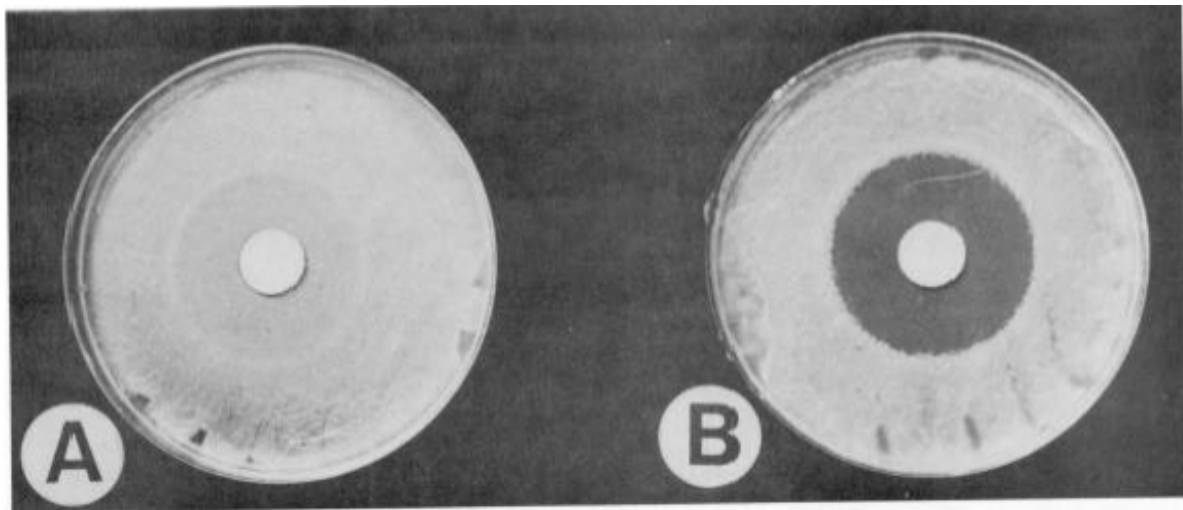

Figure 32: Zone of Inhibition of Propiconazole on Bioassay Disk (B) and the Control Disk (Water only) on left (67)

The objectives of this study were to develop a sensitive method of determining propiconazole residues in elm trees injected with Alamo, and to compare residue profiles in trees injected with different dosages and different methods of injection. We hoped that this study would provide valuable insight into dosage and treatment frequency needed to provide maximum protection against *O. ulmi*, the pathogen that causes Dutch Elm Disease.

Experimental

Fungicide

The fungicide evaluated was propiconazole, [1-[2-(2,4 dichlorophenyl)-4-propyl-1,3-dioxolan-2-yl]methyl]-1H-1,2,4-triazole. The pesticide formulation and micro-injectors were donated by Ciba-Geigy (now, Novartis, Inc.), Agricultural Division, Greensboro, NC. Both the bulk formulation and micro-injectors contained 14.3% of the active ingredient.

Trees

Field tests with propiconazole injections were performed on elms in urban and rural environments. In total, there were 9 elms treated; 6 of the 9 elms treated were located on Route 460 between Blacksburg and Pearisburg, Virginia; another elm was located on the campus of Virginia Tech and 2 were located in a residential neighborhood in Blacksburg, Va. The trees varied in trunk diameter and crown size. One of the residential elms was infected with DED.

Injection

The injections were started June 6, 1998. The following information was gathered for each tree at the time of injection included general condition and DBH. Control samples were taken and analyzed from each tree to ensure that the trees had not been previously treated with propiconazole.

Two methods methods (Table 5) were used: 3 elms were micro-injected at 10 mL/DBH (diameter breast height) in., 3 were macro-infused at 10 mL/DBH in., 2 were macro-infused at 20 mL/DBH in., and 1 macro-infused at 40 mL/DBH in. The micro-injectors delivered stock Alamo, while the macro-infusion system delivered the stock Alamo diluted in 500 mL of distilled water.

Table 5: Type of Treatment and DBH of each Elm

Tree	Type of Injection	DBH (inches)
1	Micro	10
2	Micro	6
3	Micro	19
4	Macro	10
5	Macro	8
6	Macro	12
Ford 1	Macro	42
Old Security	Macro	12
Ford 2	Macro	35

For root flare injection, the soil was removed from the base of the tree. The solution was injected into drilled holes approximately 5- 10 mm in diameter and 1 inch into the sapwood. The holes were positioned approximately 2-3 inches apart. The injection holes were drilled with a high-torque electric drill equipped with a high speed metal bit. The solution was stored in a plastic container and delivered through teflon tubing fitted with plastic injection heads. The injection heads were hammered into the holes in order to create an airtight seal to prevent “run-off” of the solution.

For the macro-injection technique the prescribed amount of the propiconazole formulation was diluted in 500 mL of deionized water. In the case of micro-injection, the injectors were inserted into the holes and pressurized. In both cases, the applicators were not removed until the solution was up-taken by the elm. Some elms that were treated by the micro-injection required a longer uptake period (24 hrs.).

Table 6: Dosage Information

Tree	Dosage mL/DBH	mL PCZ	grams PCZ	uptake time (Hours)
1	10	100	14.3	24
2	10	60	9	24
3	10	190	27	24
4	10	100	14	1
5	10	80	12	1
6	10	120	17	1
Ford 1	20	840	120	1
Old Security	20	240	34	1
Ford 2	40	1400	200	1

Sampling

Samples taken at random (68) were collected at various time intervals after 72 hours and 1, 2, and 7 months after injection to observe the translocation rate, distribution, and retention of propiconazole *in-situ*. Samples were systematically collected at 6 different areas around the crown of the tree. Once the sampling sites were established all of the subsequent samples were taken from the same point. Several different limbs were collected from the same area and the samples were combined.

Sample Preparation

The limbs were debarked and chopped into very small pieces. The wood samples were stored in plastic bags and transported to the Forestry Department at Virginia Tech where they were ground with a Wiley Mill to approximately 2 mm in size. The minced samples were stored at -20°C until analyzed.

Microwave-Assisted Extraction

The extractions were performed on a Prolabo-Soxwave 100 (Fonetenany-souis-bois, France). Five grams of the ground wood sample were weighed and loaded in to the extraction vessel, then 10 mL of methanol was added to the extraction vessel. The extraction was performed at a power of 30% for 15 minutes, optimized extraction conditions. After the extraction was complete, the sample was filtered and the sample vessel was washed with 2-5 mL of methanol. Finally, the solvent was evaporated using a nitrogen blowdown and rediluted to 1 mL with methanol.

Analysis

The extracts were analyzed using a model HP5890 Series II gas chromatograph interfaced to a model HP5971 mass spectrometer, and a HP-5MS 30 meters x 0.25 mm i.d. x 0.25 μ m film thickness, and the He carrier gas was held at a linear gas velocity of 40 cm/sec. The GC method employed a 10: 1 split injection of 1 μ L and an injector temperature of 280°C. The temperature program was as follows: 190°C with a ramp rate of 10°C/minute to 300°C with a 5 minute hold time. The mass spectrometer transfer line was held at 300°C. The mass spectrometer was operated in the selected ion mode. The mass units scanned were 69, 173, 259 amu.

Quantitation

The external standard calibration method was used to quantitate the amount of propiconazole in the wood samples. Calibration curves were constructed between .2 ppm and 200 ppm. Triplicate injections were performed of each concentration and the standard deviations were calculated for each data point. Only the calibration curves, which had correlation coefficients of .98 or better were accepted (Fig. 33).

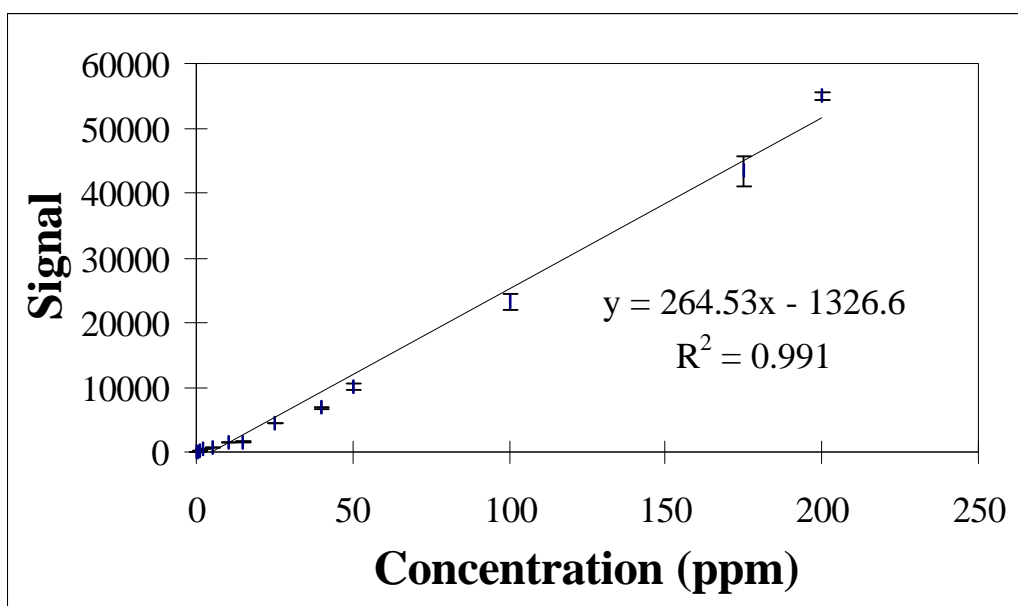

Figure 33: Calibration Curve of Propiconazole

Results and Discussion

Prior to injection control samples were collected from each tree (n= 6). The samples were extracted using MAE and the extracts were assayed using GC/MS. Propiconazole was not detected in any of the control samples (Figs. 34-36). Injections began on June 11, 1998.

Translocation

Once inside the wood tissue, translocation of systemic compounds may take place by apoplastic or symplastic routes (69). Fungicides that are translocated in the xylem vessels exhibit an apoplastic pattern of movement, while those that are translocated in the phloem have a symplastic pattern. Propiconazole exhibits an apoplastic movement, it is carried upwards to the limbs and leaves of the tree.

Translocation of propiconazole to the periphery of the crown was found possible with root-flare injection. In most cases, propiconazole had been translocated to the susceptible areas of the crown within 72 hours (Figs. 34-36). However, there were significant differences in the levels of propiconazole detected. The average concentration levels detected were between 0-40 mg/kg. The worst cases with respect to translocation were the residential elm (Ford Elm 1) and the elm on the campus of Virginia Tech (Old Security). In both cases, the root systems were confined, disturbed, or rendered dysfunctional which limited the water uptake and ultimately affected the uptake of propiconazole.

We suspected that the average rate of translocation of propiconazole using the micro-injection technique would be significantly slower than in the macro-infused elms. Seventy-two hours after the initial treatment the average concentration in the assayed wood was between 7-18 ppm in the micro-injected wood, compared to 7-40 ppm in macro-injected wood. There is no statistical difference in the translocation rate of propiconazole employing the micro-injection or the macro-injection technique.

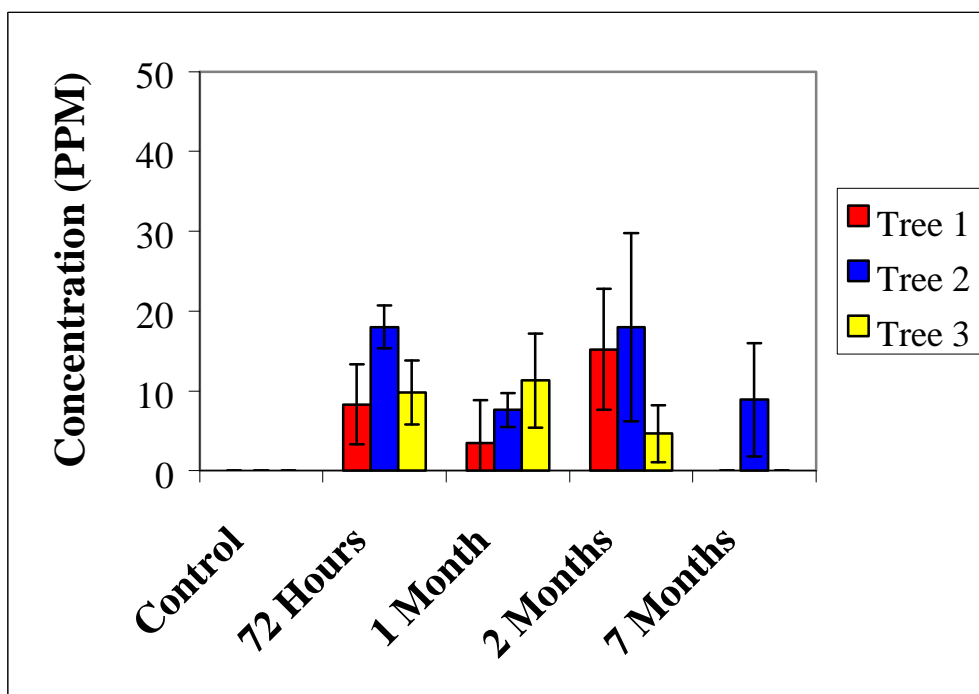

Figure 34: Average Distribution of Propiconazole in the Micro-Injected Elms at the 10 mL Dosage Rate

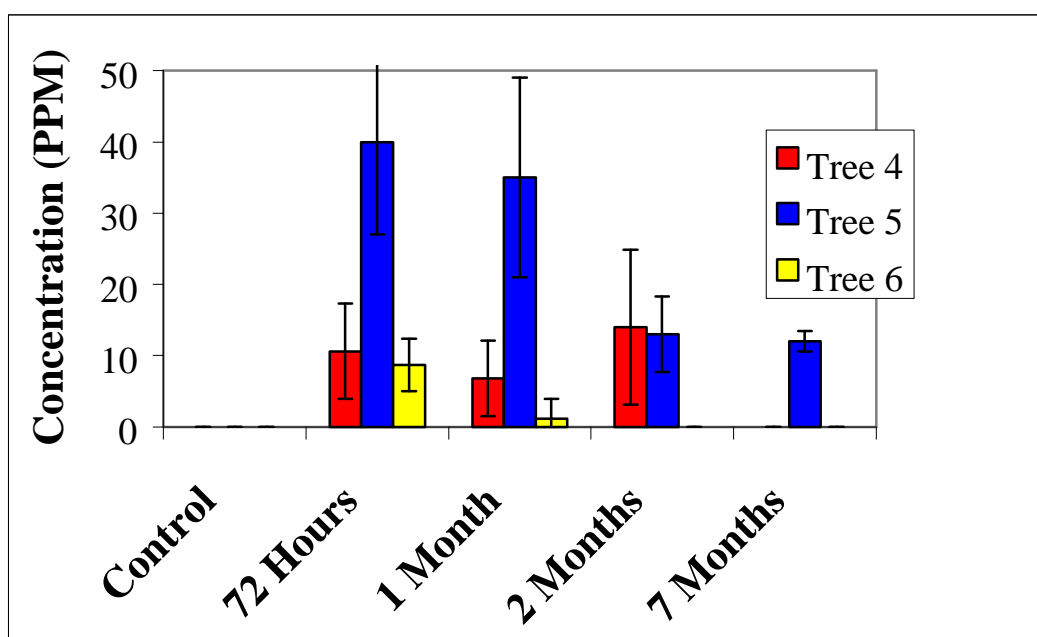

Figure 35: Average Rate of Distribution of Propiconazole in the Macro-Infused Elms at the 10 mL Dosage

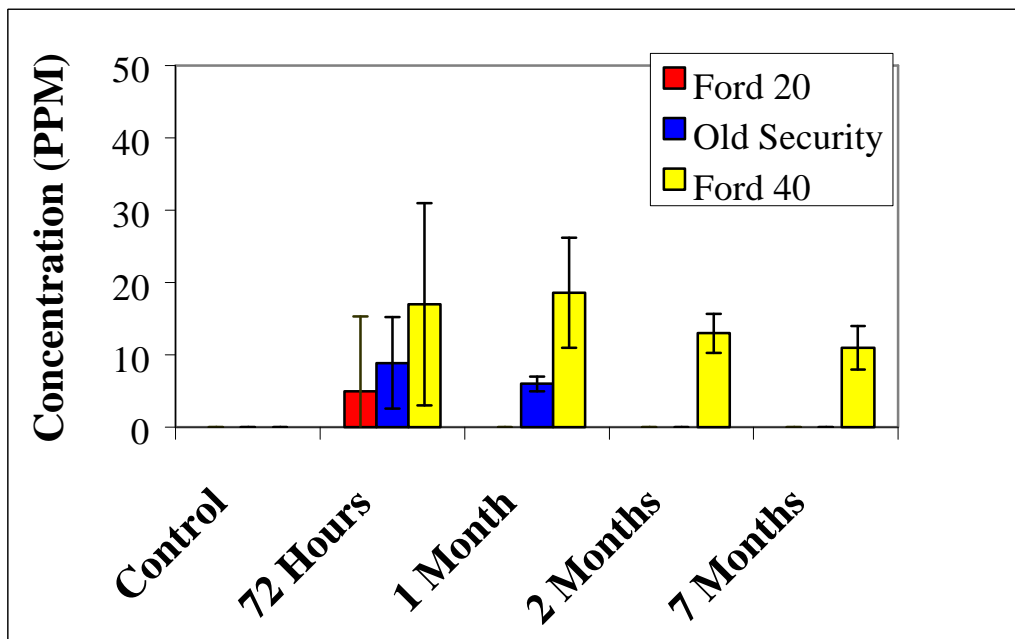

Figure 36: Average Rate of Distribution in Elms Treated with Higher Dosages; 20 mL and 40 mL/DBH

Distribution

Elliston and Walton found that MBC-P injected at ground level with injections spaced 15-23 cm apart resulted in non-uniform distribution within and between branches on a given tree (70). In this work comparable dosage rates were used but we used twice as many injection sites than Elliston and Walton, spaced 7- 10 cm apart. We observed that uniform distribution of propiconazole could be accomplished at lower therapeutic rates employing both macro-injection and micro-injection techniques. Figures 38-46 and 44 illustrate that the propiconazole was uniformly distributed throughout the tree. Except in the Ford elm (20 mL/DBH) propiconazole was not sufficiently translocated or distributed (Fig. 45). An analysis of variance (ANOVA) reveals that there is no statistical difference, $F_{\text{calculated}} = .14$ and $F_{\text{critical}} = 6.6$, in the propiconazole levels in the various samples collected from the same tree.

Residual Levels of Propiconazole

The data from the residual fate studies are complicated to interpret. The data clearly indicates that there is large degree of variability in the residue levels of propiconazole from elm to elm, $F_{\text{calculated}} = 1.77$ and $F_{\text{critical}} = 1.36$. This observed phenomena was expected and we believe that the differences in tree architecture, size, root systems, and water up-take accounted for the unique distribution patterns inside the elms.

One of the objectives of this research was to determine the rate at which propiconazole degrades over time. We expected that there would be a high initial concentration of propiconazole once all of the propiconazole had been translocated and expected the levels of propiconazole to decrease overtime. We expected that the propiconazole would be degraded through enzymatic activity or by hydrolysis; the latter will be discussed in a later chapter. In half of the treated elms, the propiconazole levels did decrease with time (Figs. 34-36). However, the average residual levels of propiconazole increased at the 2 month sampling period and then decreased (Figs. 34-36) as was the case in Tree 1, Tree 2, Tree 4, Ford 40. In the

aforementioned trees, there is a significant increase in the levels of propiconazole detected after 2 months. But in all cases the levels significantly decrease after 7 months. How could we explain this observation in our data?

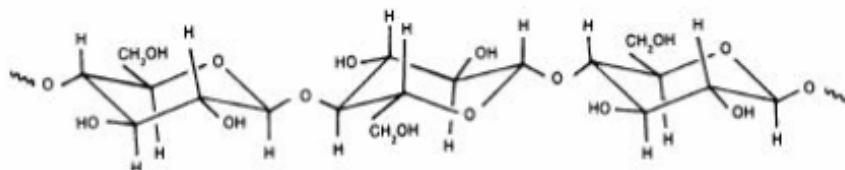

Figure 37: Structure of Cellulose

Kimball proposed that the translocation of fungicides and growth regulators is a partitioning process (65). He asserts that fungicides with the appropriate functionality can form intermolecular interactions with the cellulose material (Fig. 37) that comprise the xylem cell wall. It is envisioned that propiconazole would be adsorbed by the cell wall and temporarily immobilized due to the two polar functional groups (dioxolane and triazole moiety). For movement it must be continually “washed” off the cell wall and carried to the crown of the tree by the sap ascent. As a result, it could take as long as two months for the propiconazole to be completely translocated to the susceptible areas in the crown which may account for the increased levels of propiconazole measured at the 2-month time interval.

In some cases propiconazole was not detected in a given area of the tree. This can be attributed to two factors: architecture and detection limits. Each elm has unique architecture and conducting system; these two parameters affect how water and other materials are distributed throughout the tree. Certain areas of the tree will receive nutrients by diffusion of the materials from regions of higher concentration to regions of lower concentration, through pits in the xylem cell wall. In these regions the concentration of propiconazole present may not be present at all or be present at levels lower than the detection limit of the instrumentation used for this research, .01 ppm.

Duration

As previously mentioned, propiconazole was marketed to have therapeutic and curative activity for two years or more. In most of the elms propiconazole is not detected after 7 months (Figs. 34-36 and 38-46). Donzel and Owen proposed that propiconazole undergoes acid hydrolysis in acidic environment; elm sap is slightly acidic with a pH of approximately 6.0 (71). It will be investigated whether this is viable explanation for propiconazole not being detected for the published lifetime.

In elms treated at the recommended therapeutic dosage, 10 mL/DBH, the residue detection was very poor (Figs. 38-44). Propiconazole was not detected in 4 out of 6 of these elms at the 7 month sampling period.

Sufficient data was not collected on the elms that were treated at 2x the recommended therapeutic dosage, 20 mL/DBH. The chemicals were not adequately translocated or distributed in the elms due to the disturbed root systems. Good residual activity was noted when the elm was treated at 4x the therapeutic dosage, 40 mL (Fig.46). However, phytotoxicity is a concern when using concentrated amounts of potent fungicides.

The data suggest that dosage level for maximum residual activity should be higher than the label therapeutic dosage rate. In the elm, treated at 4x the dosage rate strong residual activity was observed. Higher dosages that are correctly injected can provide protection against *O. ulmi* for at least one growing season.

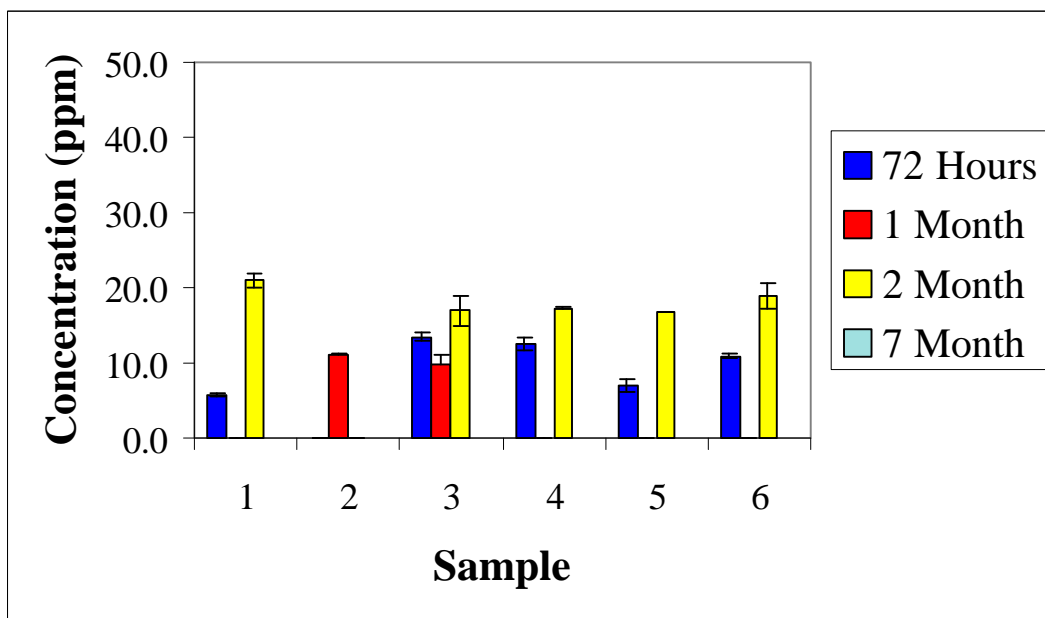

Figure 38: Translocation Pattern of Propiconazole in Tree 1.

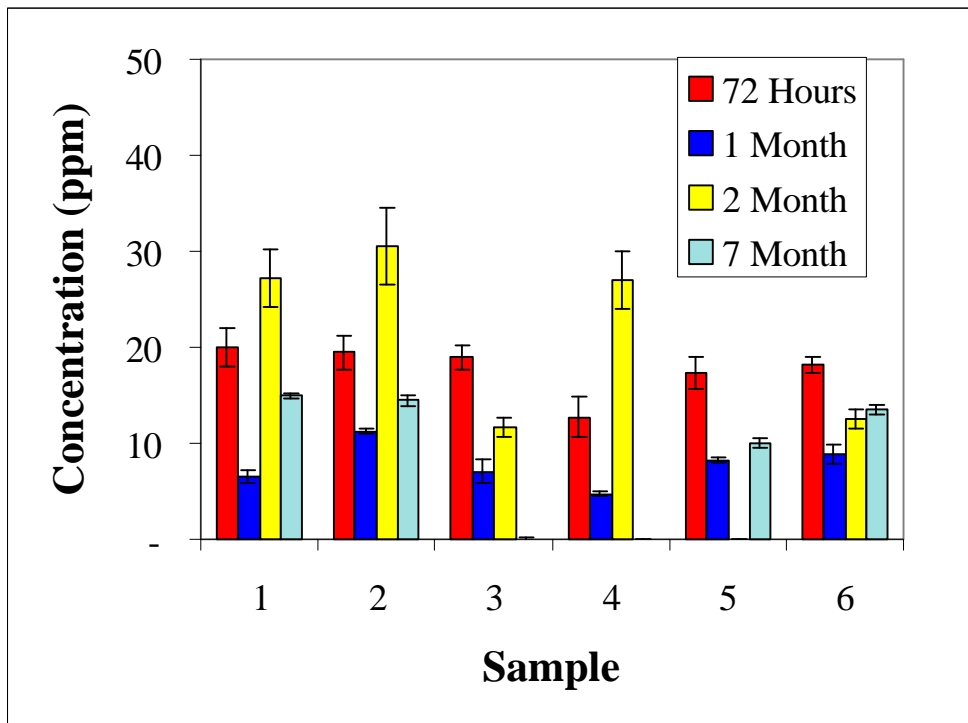

Figure 39: Translocation Pattern of Propiconazole in Tree 2

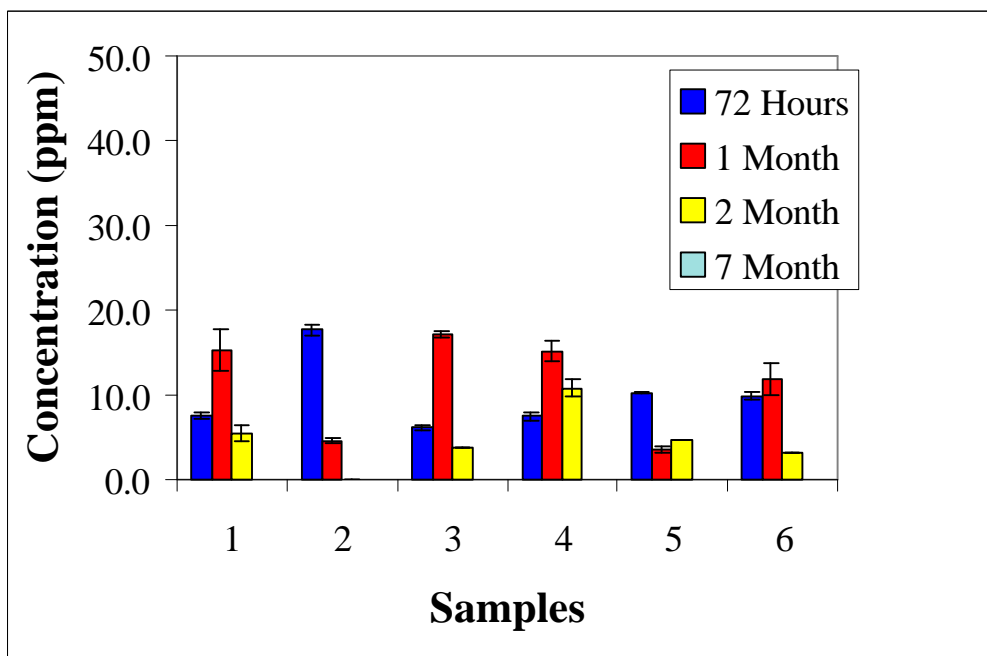

Figure 40: Translocation Pattern of Propiconazole in Tree 3

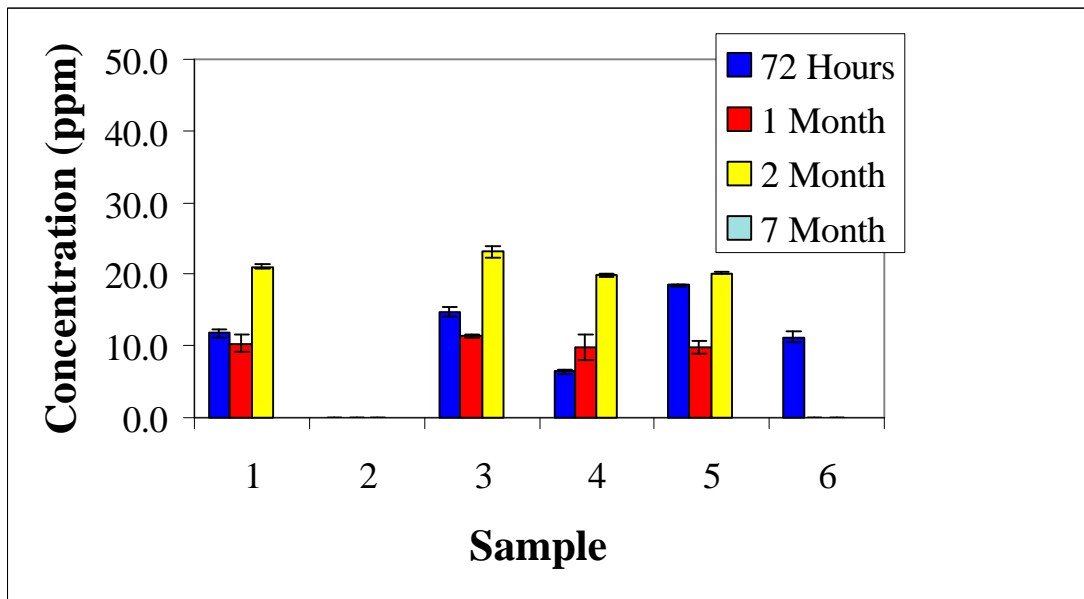

Figure 41: Translocation Pattern of Propiconazole in Tree 4

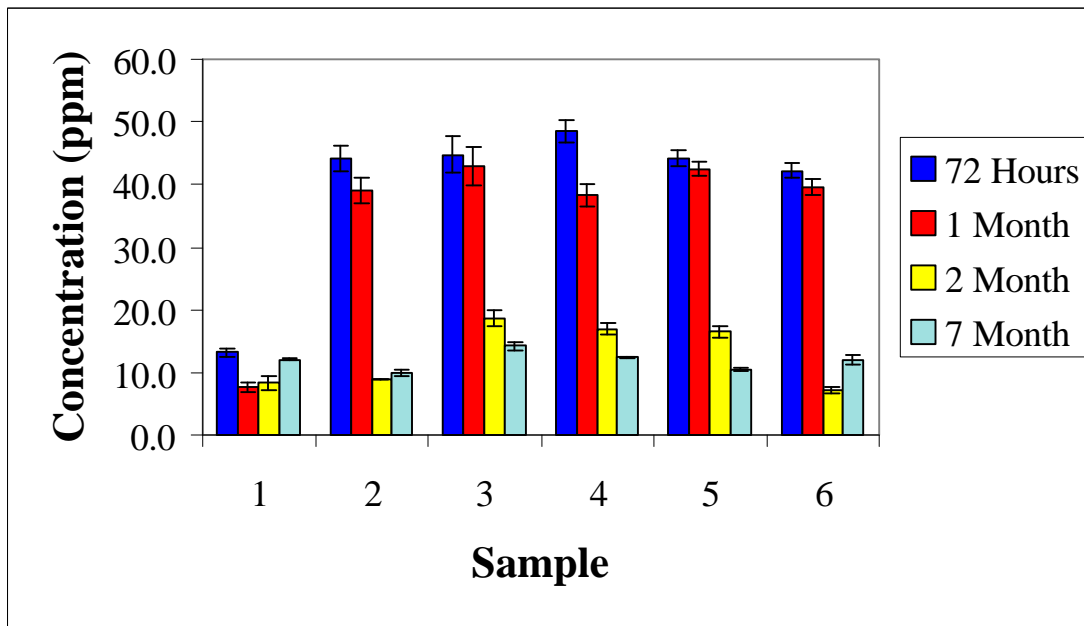

Figure 42: Translocation Pattern of Propiconazole in Tree 5

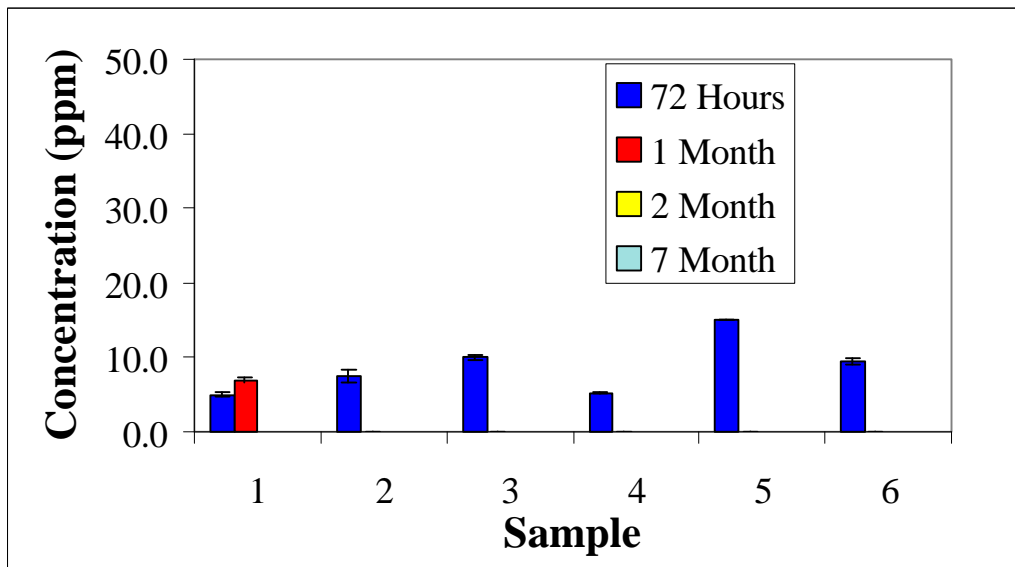

Figure 43: Translocation Pattern of Propiconazole in Tree 6

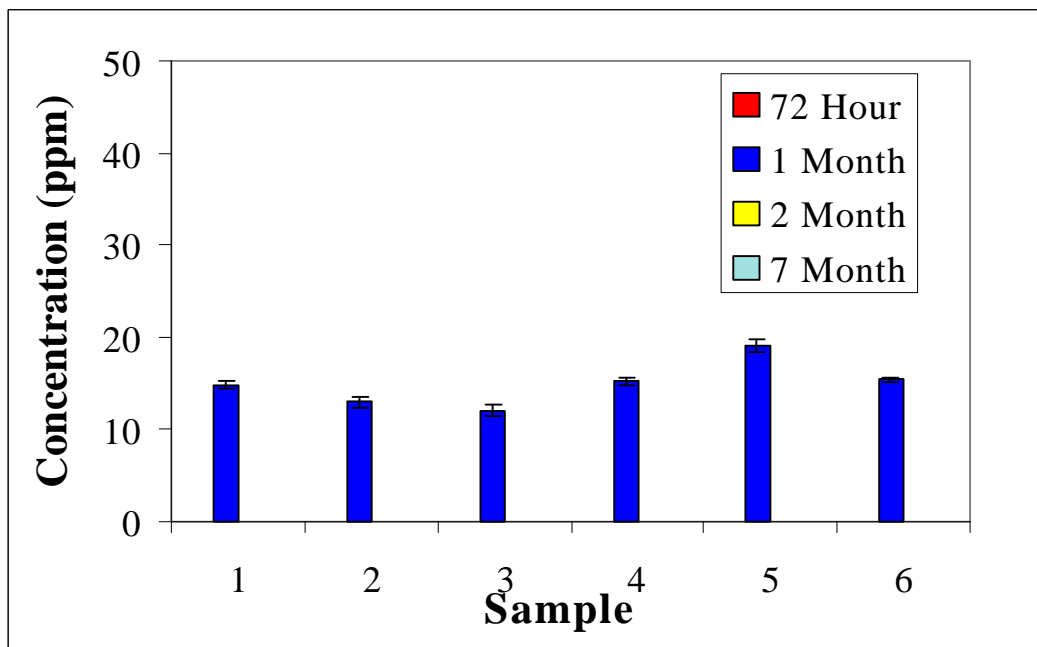

Figure 44: Translocation and Duration of Propiconazole in Elm on the Campus of Virginia Polytechnic Institute and State University

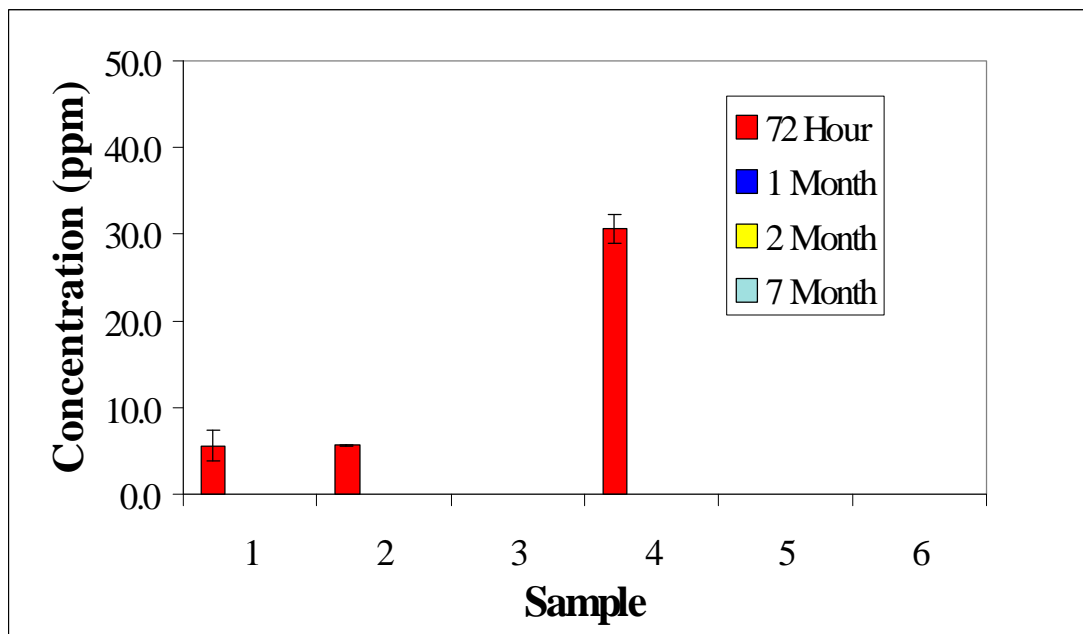

Figure 45: Translocation and Duration of Propiconazole in a Residential Elm in Blacksburg, Virginia

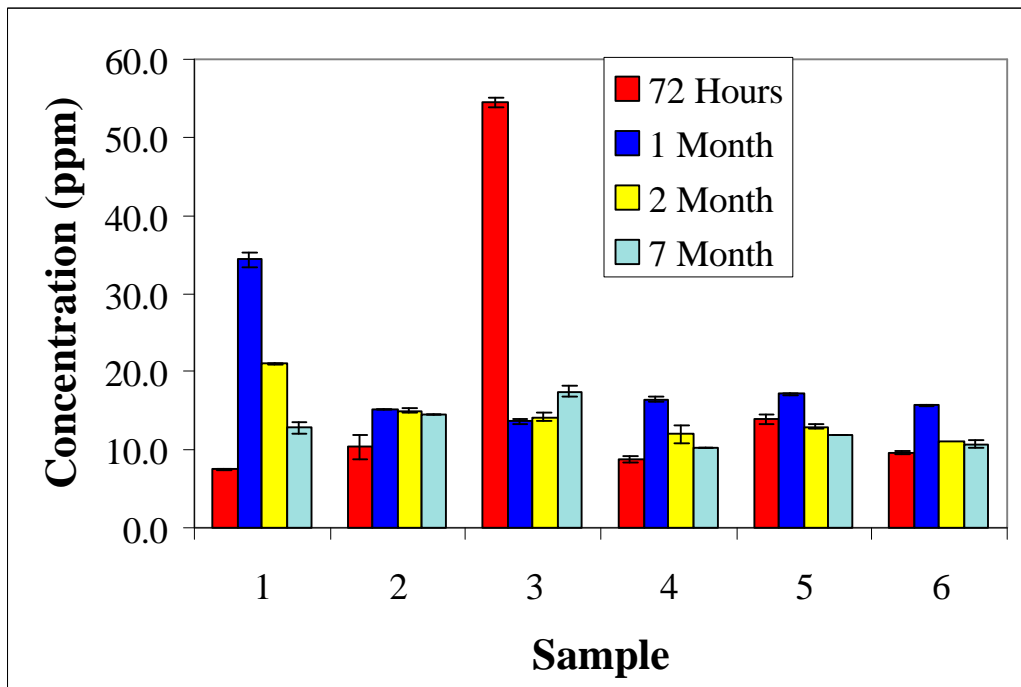

Figure 46: Translocation of Propiconazole in a Residential Elm Treated with 40 mL of Propiconazole/DBH

Conclusions

The objectives of this study were to optimize the dosage and determine the treatment frequency needed for maximum protection against *O. ulmi*. Propiconazole is mobile inside the xylem and is quickly distributed to the crown of the tree. Propiconazole was detected in the crown of the tree in 72 hours after the initial treatment and should be translocated totally after 2 months.

Using the appropriate infusion practices it is possible to get uniform distribution employing both macro-infusion and micro-injection techniques. Flare injections should be spaced at 7-10 cm apart.

There is a large variability in the concentrations detected from elm to elm. This is due to the complex diffusion processes occurring *in-situ*. Therefore it is very difficult to predict the degradation rate of propiconazole experimentally. At the recommended dosage levels propiconazole cannot be detected after 7 months in many of the elms sampled. The role of acid hydrolysis on the degradation of propiconazole will be investigated in the next chapter.

Chapter V

Degradation Studies of Propiconazole

The objective of this work was to investigate the degradation of propiconazole in wood. The residual fate studies in Chapter IV provided valuable insights into the translocation rate and distribution inside the elm. However, due to the uncertainty associated with the sampling and the complex diffusion patterns *in-situ* our data with respect to duration is inconclusive. In most cases propiconazole could not be detected in elm wood after 2 months. This could be attributed to one of two possible factors. The first, are problems inherent in the sampling technique. The second, is the degradation of the propiconazole residue by the aqueous environment inside the xylem vessels. As a result, a controlled study was used to determine the half-life of propiconazole.

This study ignores the possible degradation of propiconazole by enzymatic activity and focuses on the stability of propiconazole in an aqueous environment with similar characteristics of the elm. To date, no studies have been published on enzymatic degradation of fungicides in sap materials. It is felt that more information needs to be published about enzymes in wood before a viable experiment can be constructed.

The average pH of elm sap is approximately 6.0 (72). It was proposed by Donzel et al., that propiconazole undergoes rapid hydrolysis under acidic conditions (71). They investigated the metabolism of propiconazole in two watery agricultural products, wheat and rice. Donzel et al. determined that the half-life of propiconazole in wheat and rice is 3.5 and 14 days, respectively. They suggested that the likely metabolites of propiconazole included the three chain hydroxylation products α , β and γ -hydroxypropiconazole (71). They further concluded that these metabolites would be reduced to the corresponding carbinol (1-(2,4-dichlorophenyl)-2-(1,2,4-triazol-1-yl) ethanol under acidic conditions (Fig. 47) (71).

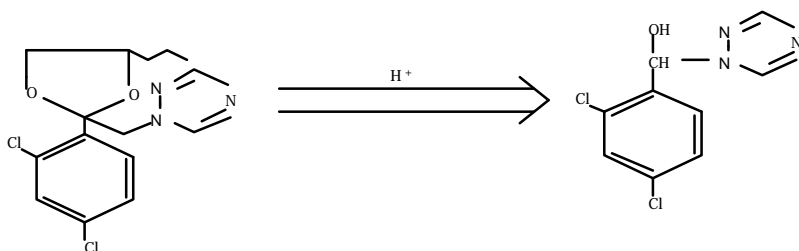

Figure 47: Proposed Degradation Pathway of Propiconazole

We felt strongly that this was a worthy study for two reasons. The first was to determine how long propiconazole persist in wood cells. For effective treatment of *O. ulmi*, a fungicide with a high degree of persistence is required because the infection period normally lasts from mid-May to late August depending on the climate (2). Secondly, we hoped that by determining the half-life of propiconazole in an aqueous environment, this would provide information regarding treatment frequency required.

To date only a few articles have been published discussing the degradation of fungicides in plant tissue. Most of the literature exploring the degradation of fungicides has been in soil systems. The general conclusions made from these studies are that in many cases there is no major qualitative difference in the degradation of the fungicides in the aqueous environment, in the actual soil or in tissue samples (71, and 73-76). Therefore, our work would seem to be a viable study for modeling the degradation of propiconazole *insitu*.

Furmidge et al. studied the degradation of selected pesticides in soil and water. He found that compounds with the appropriate functionality can be adsorbed to the soil surface. Compounds that are highly retained by the matrix often become more resistant to degradation (77).

Attempts have been made to relate pesticide structure to susceptibility to degradation (78). It is a very complicated process for plant material because adsorption is dependent on the composition of the cell wall. Cell walls composed mainly of cutins and waxes will retain mostly hydrophobic material whereas cellulosic material will retain mostly polar compounds. The rate of degradation is reduced by sorption of the analyte onto the matrix unless degradation is being catalyzed at the sorptive surface.

Most agricultural samples contain large amounts of water. As a result, adsorption becomes a competition between the cell wall and the aqueous environment. Polar chemicals with a high degree of water solubility are more easily degraded than non-polar chemicals. If the target analyte can form strong intermolecular interactions with the aqueous phase, it will remain in the aqueous phase and will not readily adsorb on the surface. This will render polar materials more susceptible to hydrolysis. Due to their hydrophobicity, non-polar materials have a tendency to adsorb to the surface of particulates and cell walls when in an aqueous environment.

Donzel et. al used this theory to explain the extreme difference in the residual levels of propiconazole in wheat and rice. They proposed that propiconazole is adsorbed by the cell wall of rice and is therefore more resistant to degradation.

Inside the xylem vessel propiconazole, exhibits rapid apoplastic movement. This seems to indicate that the relative solubility of propiconazole in solution is large with respect to the solubility of propiconazole in the cellulosic material (69). It was noted in the residual fate studies that propiconazole was translocated to the crown of the tree within 72 hours of injection. It was also noted that a small amount of propiconazole was suspected to adsorb to the cell walls. This residual amount of propiconazole was gradually removed from the cell wall surface by the ascent of sap. Due to the rapid detection of propiconazole throughout the tree system after the initial injection we feel certain that the data reflects that most of the propiconazole stays localized in the sap within the xylem vessels. Therefore, the primary concern would be to model the behavior of propiconazole in an aqueous environment.

The aim of this work was to monitor the degradation kinetics of propiconazole in water and to compare the theoretical degradation rate to the experimental rate. This was accomplished by calculating the activation energy for the degradation reaction and determining the half-life of propiconazole in an aqueous solution with a buffered pH that was held at 25C. We envisioned that this study would provide enough information to access the environmental fate of propiconazole in elm wood.

Propiconazole contains two chiral centers at the 2,4 positions of the central dioxolane ring. Propiconazole exists as 4 stereoisomers; 2 cis and 2 trans isomers. Efforts have been undertaken to separate the 4 stereoisomers on both cyclodextrin and

Pirkle type stationary phases (79). To date these efforts have been unsuccessful. However, baseline resolution of the diastereomers of propiconazole can be achieved without the use of chiral stationary phases. Both isomers are biologically important because they both exhibit antifungal activity. Therefore, degradation of both isomers was monitored.

To date no kinetics studies of propiconazole or other triazole fungicides has been reported in the literature. The purpose of the study is to investigate how environmental factors such as temperature and pH are related to the persistence of propiconazole in the xylem vessels.

Experimental

Standard Preparation

A propiconazole standard of 95% purity was purchased from Chem Service Inc. (West Chester, PA). A 2000 ppm sample was prepared by weighing the appropriate amount of propiconazole in a volumetric flask and diluting it with methanol (25 mL).

Preparation of Water Solution and Degradation Conditions

The aqueous hydrolysis rates were determined using a modification of the method described by Freed et al. (73). The initial concentration of propiconazole was half of the aqueous solubility limit (half-saturated). The solutions were prepared using the following technique: 3 mL of the 2000 ppm propiconazole standard was placed in a 100 mL round bottom flask and evaporated to dryness using a nitrogen blowdown. Deionized water was retrieved from the chemistry department stockroom; the water was sterilized by boiling vigorously for 10 minutes. The water was allowed to cool to room temperature and then 20 mL was added to the reaction flask. The solution was mixed vigorously for 10 minutes. Finally, the solution was pH adjusted to 6.0 with 10 mL of a buffer solution (sodium hydroxide-potassium monophosphate). The buffer solution was purchased from Fisher Scientific Inc. (Fairlawn, New Jersey).

The temperature of the vessels was maintained at 25°C, 50°C, 80°C and 100°C using an oil bath. Prior to starting each analysis the temperature of the oil bath was monitored for a 2 day period. The temperature inside the bath usually stayed within ± 3 °C of the set temperature. The solution and the oil inside the bath were stirred constantly throughout the course of the experiment with a magnetic stirrer. Aliquots of 2 mL were periodically taken from the samples, solvent extracted with dichloromethane, and analyzed by GC/MS. At least 24 hours was allowed between sampling periods to enable the system to achieve equilibrium.

Extraction Procedure

One mL of the reaction solution was taken at various time intervals and extracted five times with 1 mL portions of dichloromethane. The HPLC grade dichloromethane was purchased from Allied Signal, Burdick and Jackson (Muskegon, MI).

The number of extractions was adjusted experimentally to give recoveries between 90 and 96 %. Samples of water containing 200 ppm of propiconazole were extracted using the previously described technique. The recoveries were determined for the number of extractions performed. Five extractions of the water were required to produce quantitative recovery of propiconazole (Fig. 48).

The density of dichloromethane (1.2) is greater than that of water (.993). The dichloromethane layer (bottom layer) was removed with a Pasteur pipet after every extraction and placed in a separate vial. The dichloromethane extracts were combined and reduced to a residue under a nitrogen stream. The residue was diluted to 1 mL with methanol.

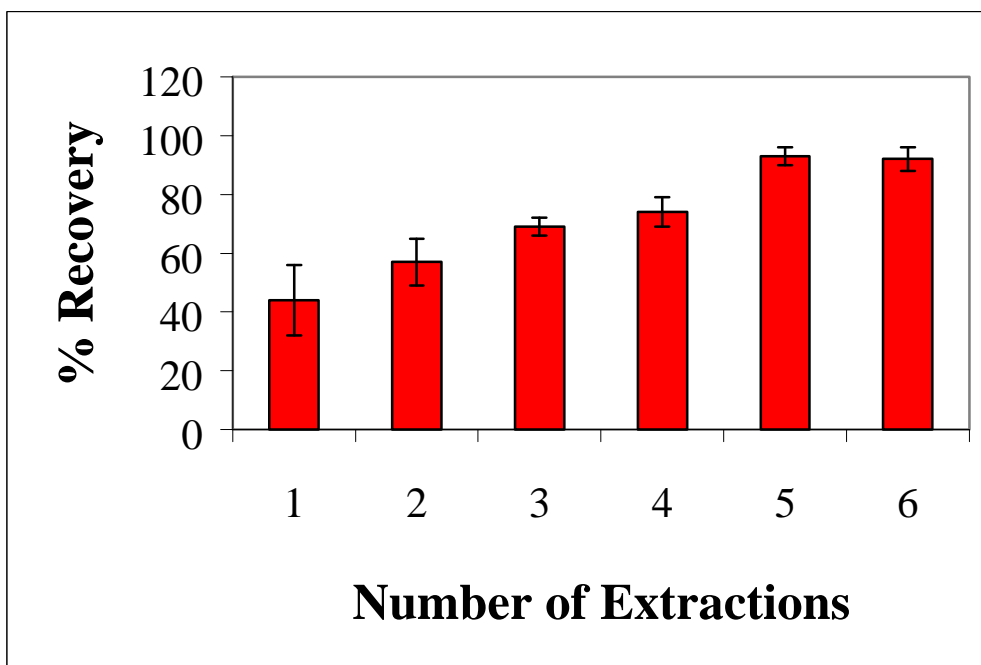

Figure 48: Extractions required for Quantitative Recovery of Propiconazole from Aqueous Matrix

Chromatographic Analysis

The extracts were analyzed using a model HP5890 Series II gas chromatograph (GC) interfaced to a model HP5971 mass spectrometer detector (MSD). The chromatographic system was equipped with a HP model 7673 auto-sampler. The column used was a HP-5, 5% phenyl and 95% methyl polysiloxane; the dimensions were 30 meter x .25 mm i.d. x .25 μ m film thickness. Helium was used as the carrier gas and was held at a linear velocity of 40 cm/sec. The GC method employed a 50: 1 split injection of 1 μ L and an injector temperature of 280°C. The temperature program was expanded so that any degradation products with shorter analysis times would be identified. The temperature program was as follows: 80°C with a ramp rate of 10°C/min to 300°C with a 5 minute hold time. The mass spectrometer was operated in the scan mode so that all degradation products could be identified. Quantitation was performed using the external standard calibration procedure. Calibration curves were constructed by plotting the peak areas of standards versus the concentration. Only calibration curves with correlation coefficients of .98 or better was accepted.

Kinetic Experiments

A total of 2 mL of water was sampled at the beginning (time=0), and after 1, 2, and 4 days then once a week until the reaction was nearly complete. The degradation of both stereoisomers of propiconazole was monitored.

Due to the time-consuming sample handling; sampling, solvent extraction, drying, concentration, and analysis no replicates were performed. Triplicate analyzes were performed and relative standard deviations was determined for the injection procedure. Error bars were not added to graphs because they would be reflective only of the precision and not the accuracy of the technique.

The reaction-order was determined by curve fitting. The data was fitted with first-order and second-order degradation kinetics (Eq. 8 and 9).

$$\log[A] = \left(-\frac{k}{2.30}\right)t + \log[A]_0 \quad \text{Eq. 8}$$

The correlation coefficients were .89 to .91 and .94 to .99, respectively. Due to the higher correlation coefficients it is concluded that propiconazole undergoes a second-order degradation process. The chemical degradation of propiconazole can be described by using a second-order degradation curve (eq. 9) (80).

$$\frac{1}{[C]} = \frac{1}{[C]_0} + kt \quad \text{Eq. 9}$$

Where, C_t is the concentration of propiconazole at time t , C_0 is the initial concentration, and k is the rate constant. By plotting $1/C_t$ versus time, a straight line can be obtained and the rate constant is equal to the slope of the line. The half-life, $t_{1/2}$, corresponds to a period of time at which the pesticide concentration is equal to half of the initial concentration (eq. 10) (80).

$$t_{1/2} = \frac{1}{k[C]_0} \quad \text{Eq. 10}$$

The rate constants were determined at four different temperatures; 25°C (298 K), 50°C (323 K), 80°C (353 K) and 100°C (373 K). By calculating the rate constants at different temperatures the activation energy, E_a , can be determined using the Arrhenius equation (eq. 2, pg. 23), where T is temperature, A is the frequency factor, and R is the gas constant. The E_a value demonstrates the influence of temperature on the degradation of propiconazole. The larger the E_a the more the reaction is dependent on temperature. As a result, the degradation kinetics increases as temperature increases.

Results and Discussion

In the present study, the hydrolysis rate constants of propiconazole in neat water was determined. Several authors (71 and 79) have reviewed the mechanism of hydrolysis. However, kinetic data in aqueous matrices are still scarce. There are many

factors which affect or enhance the hydrolysis rate of propiconazole in sap. It is expected that insight into the persistence of propiconazole can be revealed when the hydrolysis rates are known.

The rate constants (Fig. 49 and 50), half-lives, and activation energies were calculated from linear regression data using Kaliedagraph and Excel software. The correlation coefficients, r , ranged from .96 to .99. All of these values show good correlation.

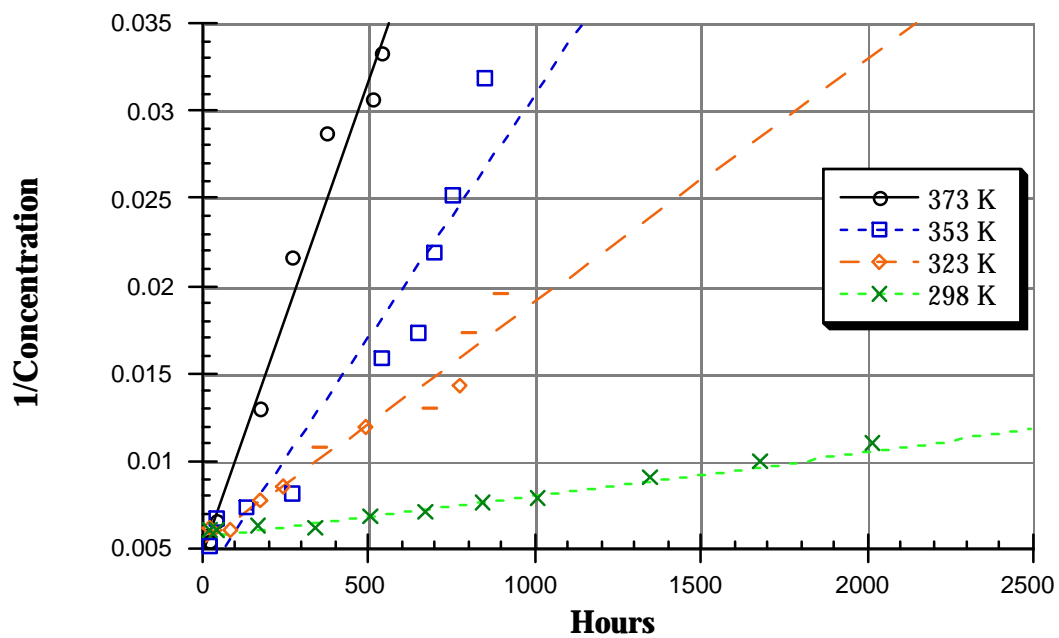

Figure 49: Rate Curves at 298 K, 323 K, 353 K, and 373 K for Hydrolysis of Propiconazole Isomer (cis).

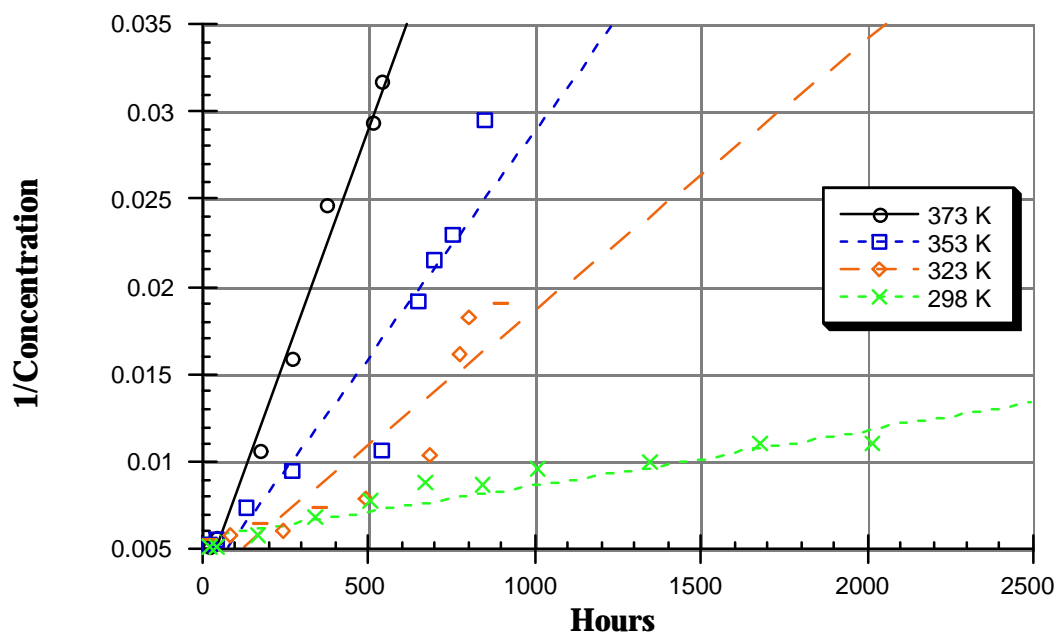

Figure 50: Rate Curves at 298 K, 323 K, 353 K, and 373 K for Propiconazole Isomer (trans).

Figures 49 and 50 show the disappearance of propiconazole with respect to time under defined temperature and pH conditions. The half-lives and rate constants for the degradation of propiconazole in a buffered solution at temperatures of 298 K, 323 K, 353 K, and 373 K are listed in Table 7 and 8. As expected, the degradation rate of propiconazole increased with increasing temperature. At room temperature the half-life for the cis isomer is 101.6 days but when the temperature of the reaction is increased to 373 K the half-life ($t_{1/2}$) is only 4.2 days. This degradation pattern is similar for the trans isomer. The half-life of trans isomer is significantly shorter than the cis isomer; except at 353 K (see table 7 and 8). This phenomenon is consistent with the literature. Hadjidemetriou et al. determined that the trans stereoisomer of propiconazole is metabolized slightly faster than the cis isomer (81).

Table 7: Kinetic Data for Propiconazole Isomer (cis)

Temperature (K)	Initial Concentration	Rate Constant (hours ⁻¹)	Half-lives (Days)
298	164	2.50×10^{-06}	101.6
323	163	1.38×10^{-05}	18.7
353	194	2.775×10^{-05}	7.7
373	185	5.465×10^{-05}	4.2

Table 8: Kinetic Data for Propiconazole Isomer (trans)

Temperature (K)	Initial Concentration	Rate Constant (hours ⁻¹)	Half-lives (Days)
298	196	3.14×10^{-06}	67.8
323	178	1.542×10^{-05}	15.2
353	192	2.58×10^{-05}	8.4
373	196	5.243×10^{-05}	4.0

The temperature within the elm is normally maintained between 20°C (293 K) to 25°C (298 K) during the summer months. If the elm is treated at the appropriate time (early-May) and good injection practices are used, then the elm should be protected throughout the infestation period. The theoretical half-life of propiconazole at 25°C (298 K) was determined to be between 67 and 101 days. This information seem to be in reasonable agreement with the experimental residual fate studies because in most cases propiconazole could not be detected after the two month sampling period.

Activation Energy

The activation energy is a parameter, which describes the temperature dependence of the reaction. The activation energy was calculated using the Arrhenius equation (Eq. 2, pg. 23). The activation energy for the cis and trans isomers of propiconazole at a pH of 6.0 is 5.7 kcal/mol and 6.8 kcal/mol, respectively. It must be noted that the E_a is only valid within the given temperature range (82). To date no activation energy measurement has been published in the literature for propiconazole.

$$E_a = -(\text{Slope} * R) \text{ Eq. 11}$$

Our E_a calculations indicate that temperature plays a significant role in the degradation of propiconazole. Lartiges et al. studied the degradation of triazine fungicides in soil and water (76). The triazine class of fungicides is to considered to the most stable pesticides in agricultural use. Lartiges and his companions determined that the activation energy of atrazine and cyraprazine are 1.5 and .02 kcal/mol, respectively. Therefore, temperature does not significantly effect the degradation processes and the half-lives calculated at pH of 7.3 are 164 and 190 days, respectively.

We can expect from our data that the lower the temperature the slower the degradation process. Therefore, in the winter months when the temperatures are lower the rate at which propiconazole is degraded due to hydrolysis *insitu* should be slower. This study shows that temperature is a major factor, and in cases where temperature of the tree sap is 50°C (323 K) one would expect a rapid degradation of propiconazole.

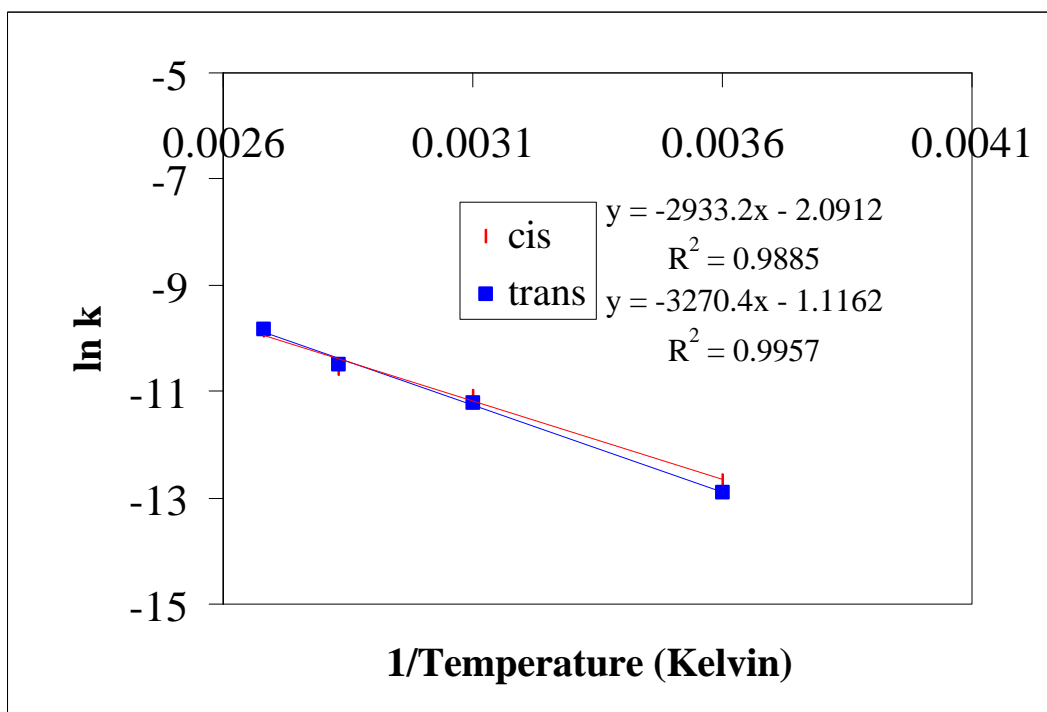

Figure 51: Arrhenius Plot of Activation Energy Parameters for Propiconazole Isomers

Observed Degradation Products

We monitored the degradation products of our reaction. However, positive identification of the degradation products was difficult due to the nature of our matrix. Two degradation products were positively identified as a metabolite of the propiconazole; 1-(2,4-dichlorophenyl)-Ethanone and pentanediol (Figs. 52 and 53). The products were identified using the Wiley MS library. The match quality was 86% and 56%, respectively. The product formed was not 1 to 1 with the parent, therefore we believe that at least one more metabolite of propiconazole exists. To date we have not been able to positively identify any other metabolites.

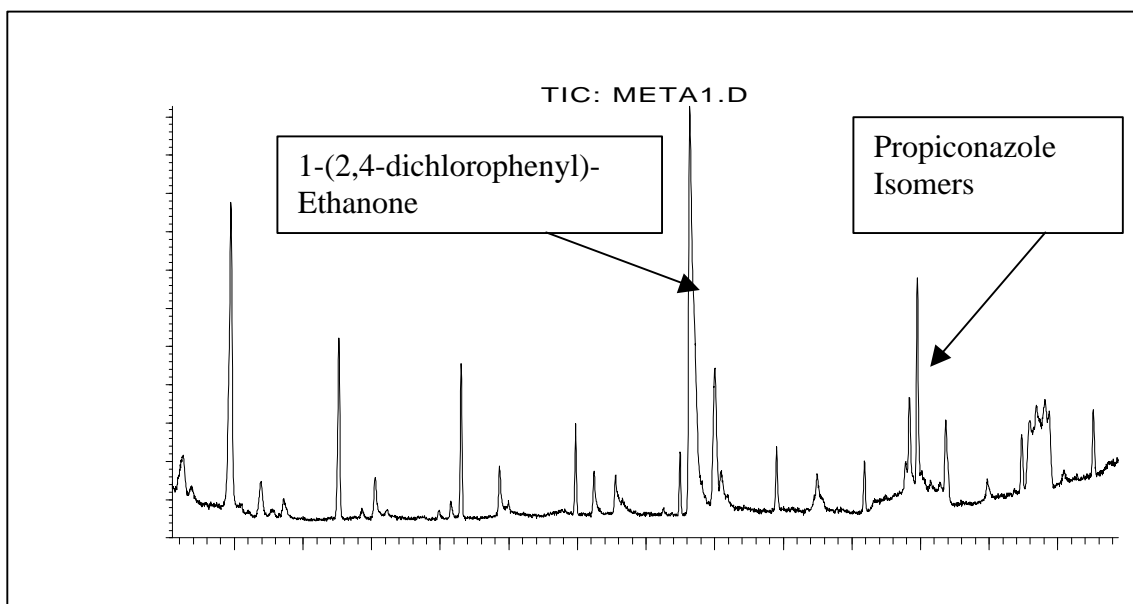

Figure 52: Total Ion Chromatogram of Degradation Products of Propiconazole

Because the study was performed in an aqueous solution, prior to chromatographic analysis liquid-liquid extraction of the organic components of the solution was performed. Some of the chromatographic peaks observed in Figure 51 are due to column bleed. A small amount of water was present in the extracts even with

careful separation of the organic layer. It was impossible to eliminate all of the water from the sample.

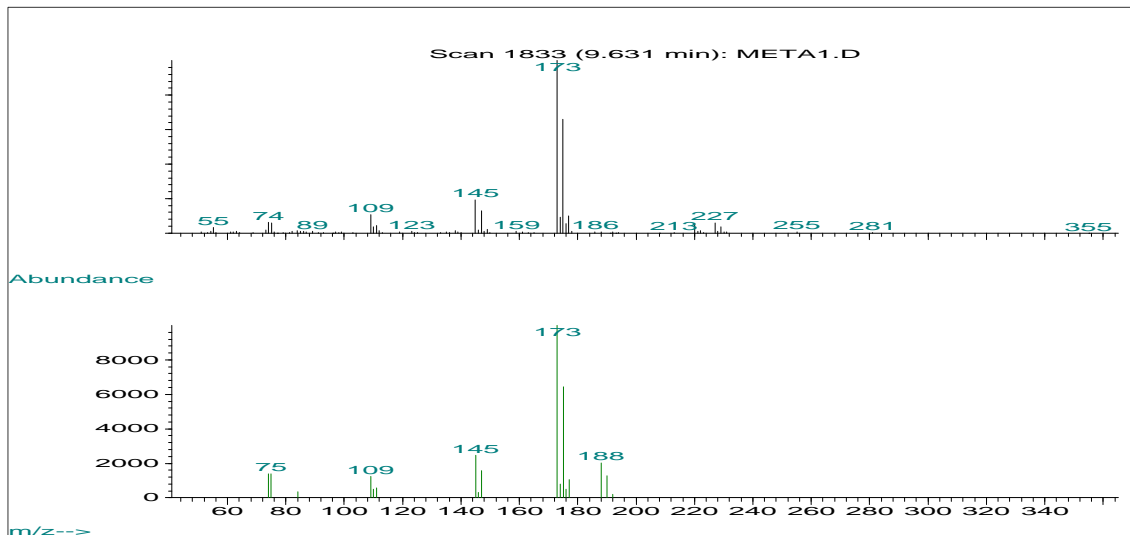

Figure 53: Confirmation of Degradation Product

It was proposed that in the degradation pathway the corresponding carbinol would be produced (Fig. 47). However, the observed degradation is different than the proposed degradation product, no carbinol was identified by GC/MS. Not only was the dioxolane moiety cleaved but the triazole portion was cleaved as well. The first step in the degradation process is hydrolysis of the dioxolane group to the corresponding carbonyl and 1, 2-pentanediol (Fig. 54).

In the presence of acid and water the triazole moiety becomes hydrated. The activity of the carbonyl causes the molecule to favor another reaction where the hydrated triazole portion behaves as a leaving group. The molecule is reduced to the corresponding ketone (Fig. 54) (83). No metabolites associated with the triazole group has been positively identified, therefore, the degradation pathway is speculation. It is possible that the metabolites of the triazole group are extremely thermally labile and not suitable for GC analysis.

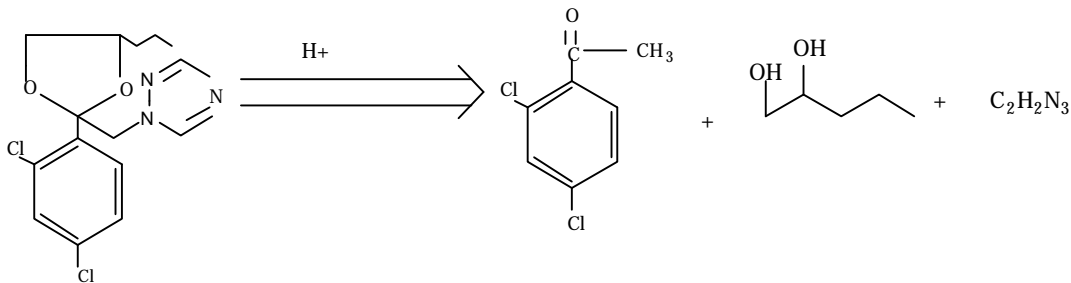

Figure 54: Experimental Degradation Pathway (84)

Only a small amount of the 1,2-pentanediol was detected. Pentanediol is azeotropic with water due to its hydrogen bonding potential this accounts for the poor extractability. 1, 2-Pentanediol was only detected when the reaction solution was injected (Fig. 55). The chromatographic quality was compromised by the column bleed cause by the oxidation of the stationary phase in the presence of water heat. Figure 56, compares the Wiley library spectrum of 1, 2-pentanediol to the sample.

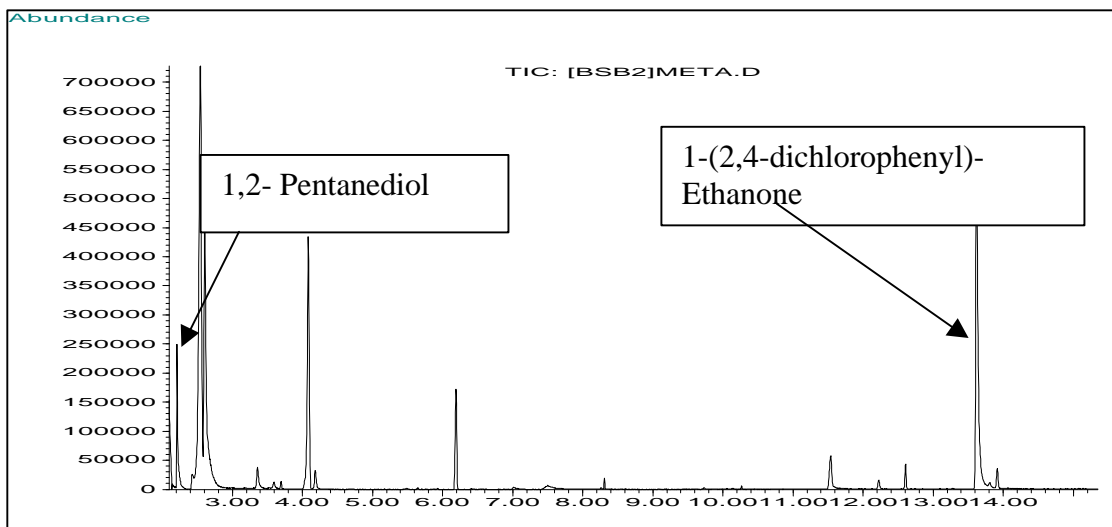

Figure 55: Total Ion Chromatogram of Neat Water Sample containing 1,2-Pentanediol

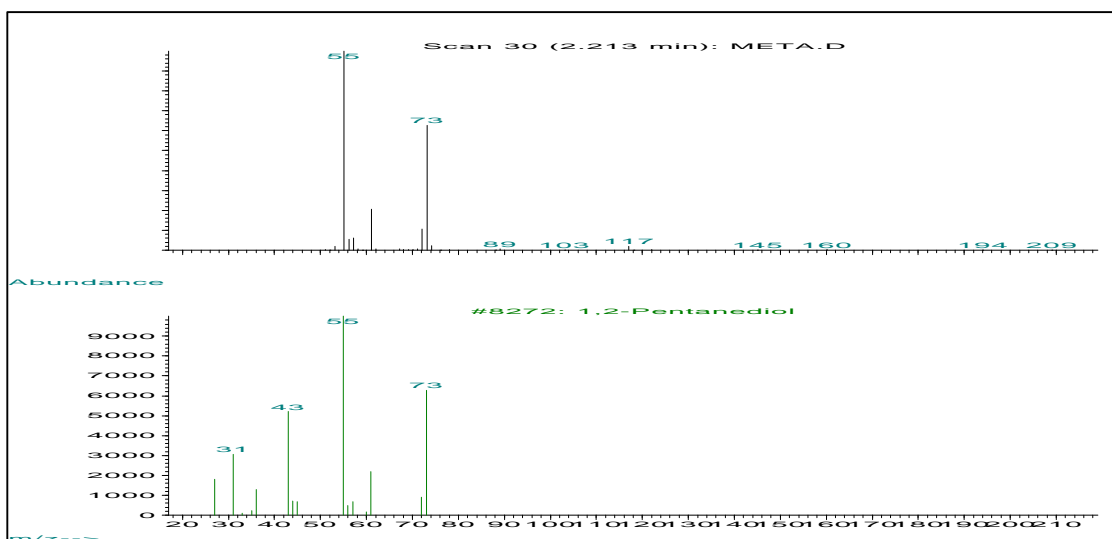

Figure 56: Library Comparison of Pentanediol

The match quality for two the spectra are 56%. We attribute our narrow scan range for the poor match. The ratio of 55 m/z and 73 m/z are nearly 1.0, which indicates that this metabolite is 1, 2-pentanediol.

We were also able to observe the degradation of propiconazole using to mass spectrometry. By enlarging the peak corresponding to 1-(2,4-dichlorophenyl) -Ethanone we able to monitor the conversion of propiconazole into its metabolite. A shoulder was observed in Figure 57 at 9.70 minutes. The mass spectrum of the shoulder (Fig. 58) contains ions that are characteristic of propiconazole (69, 173,175, and 259 m/z). This metabolite of propiconazole was not identified.

As the mass spectrums are taken across the peak the masses 69 and 259 m/z disappear indicating the disappearance of propiconazole (Fig. 59). This is direct evidence that the degradation product is directly related to propiconazole. The peak was identified as 1-(2,4-dichlorophenyl) -Ethanone.

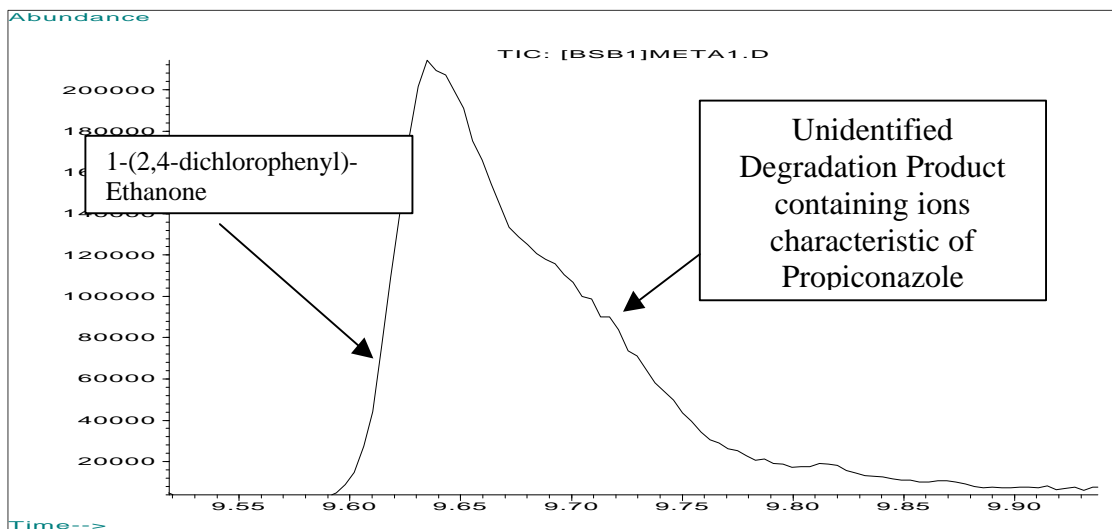

Figure 57: Enlarged Total Ion Chromatogram (TIC) of Degradation Product

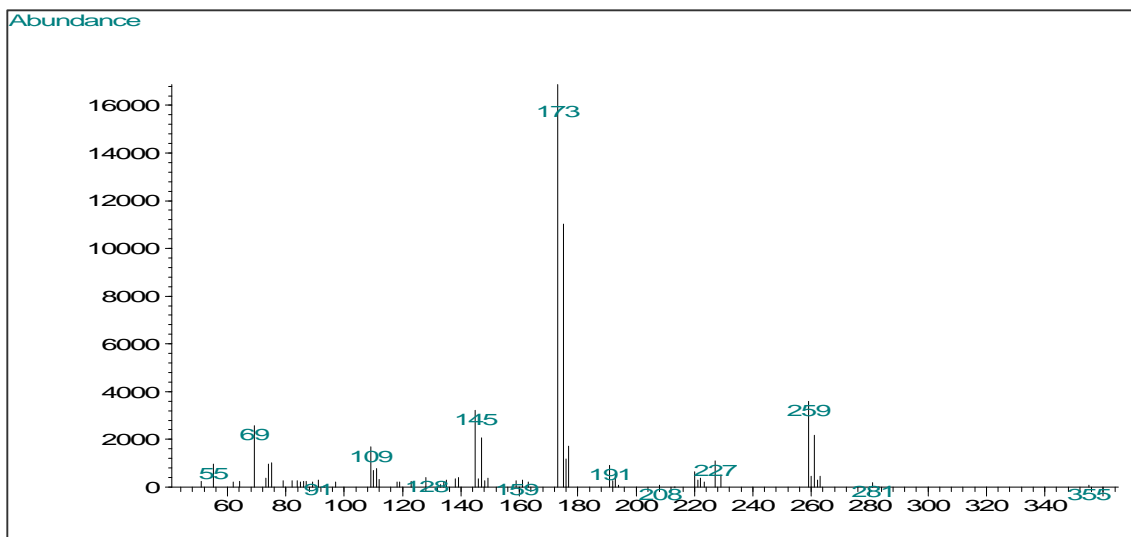

Figure 58: Mass Spectrum of Shoulder in the Total Ion Chromatogram

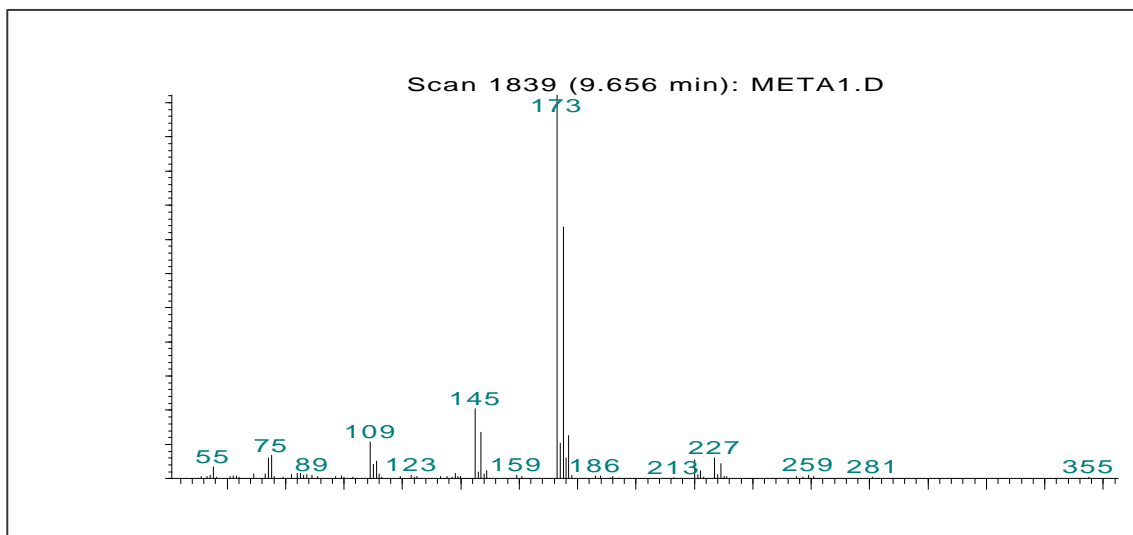

Figure 59: Mass Spectrum illustrating the Disappearance of the 69 and 259 m/z

The identified degradation products are 1-(2,4-dichlorophenyl)-Ethanone and 1,2-pentanediol (Figs. 52 and 55). The only reported biological use of 1-(2,4-dichlorophenyl)-Ethanone is for anti-microbial activity against gram positive bacteria (85).

Conclusions

The half-life of propiconazole at 25°C is 67-101 days. In the residual fate studies propiconazole cannot be detected in most elms after the 2 month sampling period. The degradation can be attributed to two main factors: hydrolysis and enzymatic degradation,

The magnitude of the activation energy, E_a , for the cis and trans isomers 5.4 and 6.8 kcal/mol indicates that the degradation rate of propiconazole is temperature dependent. The only degradation products positively identified are 1-(2, 4-dichlorophenyl)-2-Ethanone and 1,2-pentanediol. Neither degradation product exhibit anti-fungal activity against *O. ulmi*.

Chapter VI

General Conclusions

The data present in this research demonstrates the potential for Microwave-Assisted Extraction (MAE) in agricultural analysis. The traditional methods for extracting wood are tedious, time-consuming, or require large volumes of solvent. We have described a fast method for extracting trace levels of systemic fungicides from woody plant material employing MAE. The beauty of this technique resides in its applicability to a wide variety of sample types.

Focused MAE provides efficiencies similar to those obtained by Soxhlet with extractions times at least 30 times shorter (15 minutes versus 8 hours). The fact that the sample is directly irradiated with microwave energy accounts for the accelerated extraction kinetics.

Sometimes the recoveries attained are higher using MAE; this is particularly true for agricultural matrices. Due to the higher temperatures and localized superheating in matrices that contain water, using microwave extraction makes possible the release of strongly adsorbed analytes that are difficult to remove at the lower temperatures reached in the conventional extraction techniques. Most agricultural matrices contain large amounts of water, which can limit organic solvent accessibility to adsorption sites on the matrix when employing extraction techniques, such as supercritical fluid or soxhlet. With MAE the presence of water can actually speed-up the dissolution kinetics due to its efficient absorption of microwave energy and the subsequent heating.

The feasibility of MAE for the isolation of propiconazole, a polar systemic fungicide, from *Ulmus americana* (elm wood) was explored. We were successful in quantitatively recovering propiconazole from ground wood samples, which had been spiked with the fungicide. The extraction conditions: solvent strength, extraction time, extraction power and pH were all optimized. A short extraction time was required (15 minutes) and a power of 90 watts was required for quantitative recovery of propiconazole. The extracts were assayed using selected-ion monitoring GC/MS; the detection limit was calculated to be 100 ppb.

This work was undertaken because the traditional method, zone of inhibition, for detecting pesticide residues in woody plant tissues failed to detect propiconazole. Furthermore the traditional method does not yield information regarding the concentrations inside the matrix. The method established in this research was used to determine the translocation, distribution, and persistence of the fungicide *insitu*.

The data clearly indicates there is no difference in the translocation rate of propiconazole when employing macro-infusion or micro-injection techniques. There are significant differences in their uptake rates, 45 minutes and 24 hours for macro-infusion and micro-injection, respectively. However, once the chemical was inside the xylem vessels our studies reveal that sufficient levels of propiconazole had been translocated to the susceptible areas in the crown of the elms within 72 hours after the initial treatment using both injection techniques. This was not the case in the Ford 1 (20 mL/DBH). We believe that the root systems in this tree were severely damaged. This limits the water up-take and subsequently effects the rate at which chemicals are distributed throughout the vascular system.

It was also observed that when good injection practices are utilized uniform distribution of propiconazole is possible employing either macro-infusion or micro-injection. For uniform distribution of the chemical, injection sites should be spaced no more than 7 to 10 cm apart.

The residual activity of propiconazole was measured for a period of 7 months. Due to the large surface area, complex diffusion patterns, and irregular shape it is impossible to correlate dosage levels with expected concentrations levels in trees. There is a large variability in the distribution of propiconazole from elm to elm and even at the different sampling periods. Strong residual activity was noted for all elms for the first two months after application. It was also observed that the residual levels of propiconazole were slightly higher at the 2 month sampling period. This is attributed to the temporary immobilization of propiconazole as it migrates up the xylem cell wall. Due to the polar functional groups on the fungicide and the “hot spots” on the xylem cell walls there is a chance that due to strong intermolecular interactions that propiconazole is immobilized and is gradually carried to the crown of the tree in the sap ascent.

At the 7 month sampling period strong residual activity was only noted in 2 of the 6 elms treated at the 10 mL/DBH and 40 mL/DBH dosage rate. Strong residual persistence in the elm treated 4x the recommended dosage was expected. Propiconazole was not detected in the other trees.

Realizing that many factors can contribute to the degradation of propiconazole *insitu* a degradation study of propiconazole in an aqueous environment similar to that of the elm was performed. It had been suggested that the dioxolane moiety would render the molecule susceptible to hydrolysis under acidic conditions. This activity would cause the molecule to degrade and lose its anti-fungal activity. The half-life of propiconazole in an aqueous environment with a pH 6.0 was determined to be 67-101 days. The only degradation product identified is 1-(2,4-dichlorophenyl)-Ethanone, which does not exhibit anti-fungal activity against *O. ulmi*.

The studies performed in this research indicate that elms treated before the beetle feeding cycle using good injection practices will be protected from becoming infected with Dutch elm disease. The hydrolysis studies reveal that the half-life of propiconazole at pH 6.0 at a temperature of 25C is 67-101 days. It is suggested that dosages are higher than 10 mL/DBH for strong residual activity throughout the winter months. Unfortunately, yearly injections are required because the zone of inhibition studies indicate that propiconazole does not diffuse radially through the xylem vessels into “new” wood.

Chapter VII

Literature Cited

Introduction

1. Mariam B. Sticklen and James L. Sherald, *Dutch Elm Disease Research: Cellular and Molecular Approaches*, pg. 9, Springer-Verlag, New York, NY (1993).
2. R.J. Stipes and R.J. Campana, *Compendium of Elm Disease*, pg. 42, American Phytopathological Society, St. Paul, Minnesota (1981).
3. Lawrence Schreiber and John W. Peacock, **Dutch Elm Disease and its Control**, pg. 2, US Department of Agriculture, Washington, DC (1979).
4. John Boyce, *Forest Pathology*, pg. 311, McGraw-Hill, NY, NY (1961).
5. R.J. Stipes, **Dutch Elm Disease: Chemical Control of Ceratocystis ulmi**, pg. 10-12, IUFRO Conference, St. Paul, Minnesota (1973).
6. Dan Neely, **Dutch Elm Disease: Sanitation and Dutch Elm Disease Control**, pg. 76-79, IUFRO Conference, St. Paul, Minnesota (1973).
7. M.H. Zimmerman, T.E. Timmell (Editor), *Xylem Structure and the Ascent of Sap*, Springer-Verlag, New York, 1983.
8. W. A. Sinclair, R.J. Campana (editors), **DED: Perspectives after 60 years**, Cornell University Agricultural Experimental Station, 8, 1 (1978).
9. R.J. Stipes and R.J. Campana, **Introduction and Evaluating liquid Fungicides for Control of DED, Methods for Control of Plant Pathogens**, American Phytopathological Society, St. Paul, Minnesota, 1986.
10. G. A. Zentmeyer, J. G. Horsfall, and P.P. Wallace, **Dutch elm Disease and its Chemotherapy**, Connecticut Agricultural Experimental Station Bulletin, 498, 70(1946).
11. D. N. Roy, J. R. Purdy, P. Ayyamperlimal, **Distribution of Methyl-Benzimidazol-2-yl Carbamate Phosphate in Elms: Effects of Chemical Properties and Formulation Variables**, Canadian Journal of Forestry, 10, 143 (1980).
12. R. J. Stipes, **Control of Dutch elm disease with artificially inoculated American elms with soil-injected benomyl, captan, and thiabendazole**. Phytopathology, 63: 735-738 (1979).
13. E. S. Kondo, **A Method for Introducing Water-Soluble Chemicals into Mature Elms**, Canadian Forestry Service, O-X-171, 1(1972).

Chapter II

14. R.E. Majors, **How Good is Your Method?**, LC-GC International, 10, 912 (1992).
15. S. B. Hawthorne, D. J. Miller, and M. S. Krieger, **Rapid And Quantitative Extraction and Analysis of Trace Organics Using Directly Coupled SFE-GC**, Journal of High Resolution Chromatography, 12, 714 (1989).

16. M. S. Perez and J. Sanz, **Gas Chromatographic-Mass Spectrometric Analysis of Volatile Compounds in Oakwood Used for Ageing of Wines and Spirits**, *Chromatographia*, 47, 427-432 (1998).
17. L.E. Garcia-Ayuso, M. Sanchez, and A. Fernandez de Alba, **Focused Microwave-Assisted Soxhlet: An Advantageous Tool for Sample Extraction**, *Analytical Chemistry*, 70, 2426-2431 (1998).
18. Michele Schantz and Steven B. Hawthorne, **Comparison of Supercritical Fluid Extraction and Soxhlet Extraction for the determination of polychlorinated biphenyls in Environmental Matrix Standard Reference Materials**, *Journal of Chromatography A*, 816, 213-220 (1998).
19. Supleco Catalog, 1998.
20. K. Ganzler and A. Salgo, **Microwave Extraction-a new method superseding traditional Soxhlet extraction**, Original Paper.
21. A. Gutierrez, J. del Rio, F. Gonzalez-Vila, F. Martin, **Analysis of lipophilic extractives from wood and pitch deposits by solid-phase extraction and gas chromatography**, *Journal of Chromatography A*, 823, 449-455 (1998).
22. M.S. Perez-Coello, J. Sanz, and M.D. Cabezudo, **Analysis of volatile components of oak wood by solvent extraction and direct thermal desorption-gas chromatography-mass spectrometry**, *Journal of Chromatography A*, 778, 427-434 (1997).
23. Scientific Instrument Service, **Application Note 1**, October, 1990.
24. William J. Irvin, *Analytical Pyrolysis-A Comprehensive Guide*, pg. 67-69, Marcel Dekker, Incorporated, NY (1982).
25. K.J. Harrington, **Determination of Paraquat in Wood using Pyrolysis and Gas Chromatography**, *Wood Science Technology*, 13, 21-28 (1979).
26. W. Horn and R. Marutzsky, **A Rapid Pyrolytical Method for the Determination of Wood Preservatives in Treated Wood**, *Fresenius Journal of Analytical Chemistry*, 348, 832-835 (1994).
27. G. Galletti, **Fiber Composition of a Neglected Wheat Species As Determined by Pyrolysis/Gas Chromatography/Mass Spectrometry**, *Journal of Agricultural Food Chemistry*, 44, 3133-3155 (1996).
28. J. L. Esteban, I. Castro, R. Morales, B. Fabrellas, and J. Sanz, **Rapid Identification of Volatile Compounds in Aromatic Plants by Automatic Thermal Desorption-GC-MS**, *Chromatographia*, 43, 63- 71 (1996).
29. J. Rodriguez, M. Hernandez, P. Bocchini, G. Galletti, and M.Arias, **Characterization by Pyrolysis/Gas Chromatography/Mass Spectrometry of the Alkalilignin Obtained from Wheat Straw Soda-cooking Effluents After Treatment with Streptomyces Strains**, *Rapid Communications in Mass Spectrometry*, 10, 1869-1872 (1996).
30. J. M. Challinor, **A Rapid Simple Pyrolysis Derivatization GC-MS method for Profiling of Fatty Acids in Trace Quantities of Lipids**, *Journal of Analytical and Applied Pyrolysis*, 37, 185-197 (1996).
31. M. Beverly, F. Basile, K.J. Voorhees, **A Rapid Approach for the Detection of Dipicolinic Acid using Pyrolysis/Mass Spectrometry**, *Journal of Analytical Applied Pyrolysis*, 24, 211(1993).

32. E. C. Goosens, D. de Jong, and U. A. Th. Brinkman, **On-Line Sample Treatment-Capillary Gas Chromatography**, *Chromatographia*, 47, 313-350 (1998).
33. A. Meyer and W. Kleibohmer, **Comparison of Supercritical Fluid Extraction with in situ Derivatization and Conventional Extraction Methods for the Analysis of Pentachlorophenol in Wood and Leather**, *Journal of Chromatographic Science*, 35, 165-168 (1997).
34. A.J. Sequeira and L.T. Taylor, **Supercritical Fluid Extraction of Wood Pulps**, *Journal of Chromatographic Science*, 30, 405-408 (1992).
35. W. Modey, D. Mulholland, H. Mahomed, and M. Raynor, **Analysis of Extracts From *Cedrela toona* by On-line and Off-line Supercritical Fluid Extraction-Capillary Gas Chromatography**, *Journal of Microcolumn Separations*, 8, 67-74 (1996).
36. Lois Jasse, **Comparison of Soxhlet, MAE and SFE, Lecture**, Virginia Polytechnic Institute and State University, 1999.
37. Medhi Ashraf-Khrosseni, **Accelerated Solvent Extraction, Lecture**, Virginia Polytechnic Institute and State University, 1999.
38. Robert Pearson, ***Kinetics and Mechanisms***, Wiley-Interscience, New York, New York, 1981.
39. J. Hildebrand, ***Solubility***, American Chemical Society, New York, New York, 1924.
40. J.R. Dean, E. Ludkin and A. Santomaria-Rekondo, **Accelerated Solvent Extraction of Phenols from Soil**, *Analytical Communications*, 33, 413 (1996)>
41. R. R. Bowan, **Dissolution of Metals- Theory and Technology**, *IEEE Trans. Microwave*, 24, 1976.
42. K. Ganzler and A. Salgo, **MAE: Novel Sample Preparation Method for Chromatography**, *Journal of Chromatographic Science*, 371, 299-306 (1986).
43. K. Ganzler and A. Salgo, **MAE: Novel Sample Preparation Method for Chromatography**, *Z. Lebensm. Uters. Forsch*, 184, 247 (1987).
44. Onsuka and Terry, **Extraction of Pesticides from Sediments Using a Microwave Technique**, *Chromatographia*, 36, 189-194 (1993).
45. J. Pare and J. Belanger, **MAP-A New Tool for the Analytical Laboratory**, *Trends in Analytical Chemistry*, 113, 176-184 (1994).
46. H. M. Kingston and L.B. Jassie (Editors), ***Introduction to Microwave Sample Preparation***, American Chemical Society, Washington, DC, 1998.
47. A. Zlotorzynski, **The Application of Microwave Radiation to Analytical and Environmental Chemistry**, *Critical Reviews in Analytical Chemistry*, 25, 43-75 (1995).
48. S.J. Haswell and H.M.Kingston (Editors), ***Microwaved-Enhanced Chemistry***, American Chemical Society, Washington, DC, 1997.
49. A. Krstulovic and P. Brown, **Reversed-Phase High Performance Liquid Chromatography: Theory and Practice and Biomedical Applications**, Wiley Interscience, New York, 1982.
50. C. Poole and S. Poole, **Trends in Extraction of Semivolatile Compounds for Environmental Analysis**, *Analytical Communications*, 33, 11H-14H (1996).

51. V. Lopez-Avila and R. Young, **Microwave-Assisted Extraction of Organic Compounds from Standard Reference Soils and Sediments**, *Analytical Chemistry*, 66, 1097-1106 (1994).

Chapter III

52. J. Fish and R. Revesz, **Microwave Solvent Extraction of Chlorinated Pesticides from Soil**, *LC-GC*, 14, 230 (1996).
53. C. Molins, E. A. Hogendoorn, H. Heusinkveld, P. Van Zoonen, and R. A. Bauman, **Effects of Organic Matter Content in the Trace Analysis of Triazines in Various Types of Soils with GC-NPD**, *Chromatographia*, 48, 450 (1998).
54. P. A. Urech, **Synthesis of Propiconazole**, *Pro. Br. Crop Protection Conference*, 2, 508 (1979).
55. D. Erney, T. Palowski, and C. Poole, **Matrix-Induced Peak Enhancement of Pesticides in Gas Chromatography: Is there a Solution?**, *Journal of High Resolution Chromatography*, 20, 376 (1997).
56. G. Long and J.D. Winefordner, **Limit of Detection: A Closer Look at the IUPAC Definition**, *Analytical Chemistry*, 55, 712A (1983).
57. J. Rydberg, C. Musikas, G. Choppin (Editors), **Principles and Practices of Solvent Extraction**, MerceL Dekker, New York, New York, 1992.
58. M. T. LaFuente and J. L. Tadeo, **GLC Multiresidue Analysis of Postharvest Fungicides in Citrus Fruits**, *Fresenius Z Analytical Chemistry*, 328, 105 (1987).
59. N. Crosby, J. Day, W. Hardcastle, D. Holcombe, and R. Treble, **Quality in The Analytical Chemistry Laboratory**, John Wiley and Sons, Chichester, England, 1995.

Chapter IV

60. M. A. Stennes and D. W. French, **Distribution and Retention of Thiabendazole Hypophosphite and Carbendazim Phosphate Injected into Mature Elms**, *Phytopathology*, 77, 707 (1987).
61. D. N. Appel, **Intravascular Injection with Propiconazole in Live Oak for Oak Wilt Control**, *Plant Disease*, 76, 1120 (1992).
62. R. J. Stipes and R. J. Campana, **Methods for Evaluating Pesticides for Control of Plant Pathogens**, The American Phytopathological Society, St. Paul, Minnesota, 261-265.
63. A. E. Dimond and G. H. Plumb, E. M. Stoddard and J. G. Horsfall, **An evaluation of chemotherapy and Vector control by Insecticides for Combatting Dutch Elm Disease**, *Conn. Agric. Experiment Station, Bull.* 531, 69 (1949).
64. K. Kuck and H. Scheinflug, **Sterol Biosynthesis Inhibitors and Anti-Feeding Compounds**. Springer-Verlag, Berlin, Germany, 65-96 (1986).
65. S.L. Kimball, **The Physiology of Tree Growth Regulators**, *Journal of Arboriculture*, 16, 39 (1990).
66. W. S. Washington, V. Hood, F. Goubran, G. Hepworth, and S. Stewart-Wade, **Effects of Fungicides Applied as Foliar Sprays and Trunk Injections on Nut**

- Rot of Chestnuts caused by *Phomopsis castanea* in Victoria**, Australian Journal of Experimental Agriculture, 38, 295 (1998).
67. R.J. Stipes and D. Janutolo, **Response of Aggressive versus Non-Aggressive Isolates of *Ceratocytis ulmi* to Benzimidazole and Carbamate Fungitoxicants**, Virginia Journal of Science, 1979.
 68. **Personal Communication**, Professor Tissue and Professor Long, Blacksburg, Va., 1997.
 69. H. Cottrell (Editor), *Pesticides on Plant Surfaces*, J. Wiley and Sons, New York, New York, 1987.
 70. J.E. Elliston and G. S. Walton, **Distribution and Persistence of Methyl 2-Benzimidazole Carbamate Phosphate injected into American Elms**, Phytopathology, 69, 1235(1979).
 71. Owen and Donzel, **Oxidative Degradation of Chlortoluron, Propiconazole, and Metalaxyl in Suspension Cultures of Various Crop Plants**, Pesticide Biochemistry and Physiology, 26, 75(1988).

Chapter V

72. **Personal Communication**, Dr. Stipes, Blacksburg, Va., 1998.
73. V. Freed, C. Chiou, and D. Schmedding, **Degradation of Selected Organophosphate Pesticides in Water and Soil**, Journal of Agricultural Food Chemistry, 27, 707(1979).
74. G.H. Davidonis, R. H. Hamilton, and R. O. Mumma, **Metabolism of 2,4-dichlorophenoxyacetic acid in Soybean Root Callus and Differentiated Soybean Root Cultures as a function of Concentration and Tissue Age**, Plant Physiology, 62, 80 (1978).
75. S.K. Weber, **Persistence of Organophosphate Pesticides in Estuarine Water, Water Resources**, 10, 237(1976).
76. S. Lartigis and P. Garrigius, **Degradation Kinetics of Organophosphorus and Organonitrogen Pesticides in Different Waters under Various Environmental Conditions**, Environmental Science and Technology, 29, 1246 (1995).
77. C. G. Furnidge and J. M. Osgerby, **Persistence of Herbicides in the Soil**, Journal of Science, Food, and Agriculture, 18, 295(1967).
78. R. Hague and V. H. Freed (Editors), *Environmental Dynamics of Pesticides*, Plenum Press, New York, New York, 1974.
79. Wai-on-Lee and Siu-kay-Wang, **Simple and Rapid Method for Simultaneous Gas Chromatographic Determination of Bitertanol, Metalaxyl, Oxadixyl, Propiconazole, and Triadimefon Residues in Cucumbers**, Analyst, 120, 2475(1995).
80. P. Atkins, *Physical Chemistry 5th Edition*, W. H. Freeman and Company, New York, New York, 1994.
81. D. Hadjidemetriou and T. Loeffler, **Metabolism of the Individual Stereoisomers of Propiconazole**, Journal of Crop Protection, 10, 151(1993).

82. I. Falah and W.E. Hammers, **The Kinetics of the Hydrolysis of Organophosphorus and Carbamate Pesticides in Water**, Toxicological and Environmental Chemistry, 42, 9(1994).
83. **Personal Communication**, Dr. Stephan Mabic, Blacksburg, Va., 1999.
84. **Written Communication**, Dr. David Elkins, Professor, Morgantown, West Virginia, 1998.
85. Y. Rival, G.Grassy, G. Michel, CPBTAL, Chemical Pharmacology Bulletin, 40, 1170(1992).

Chapter VIII

Appendix I: Residual Concentrations of Propiconazole (Chapter IV)

Table 9: Blank Data for Elm 1

	ppm	ppm	ppm	Average	C. Avg	SD
1	0	0	0	0	0	0
2	0	0	0	0	0	0
3	0	0	0	0	0	0
4	0	0	0	0	0	0
5	0	0	0	0	0	0
6	0	0	0	0	0	0

Table 10: 72 Hours for Elm 1

	ppm	ppm	ppm	Average	C. Avg	SD
1	2.1	2.6	2.3	2.3	5.8	0.24
2	0	0	0	0	0	0
3	6.1	7.0	6.6	6.6	13.5	0.44
4	7.0	6.1	5.2	6.1	12.5	0.86
5	4.3	2.9	3.4	3.4	7.0	0.79
6	4.9	5.5	5.4	5.4	10.9	0.36

Table 11: 1 Month for Elm 1

	ppm	ppm	ppm	Average	C. Avg	SD
1	0	0	0	0	0	0
2	5.3	5.8	5.4	5.5	11.3	0.26
3	8.7	6.5	6.1	7.1	9.7	1.38
4	0	0	0	0	0	0
5	0	0	0	0	0	0
6	0	0	0	0	0	0

Table 12: 2 Month for Elm 1

	ppm	ppm	ppm	Average	C. Avg	SD
1	17	17	15	16	21	1
2	0	0	0	0	0	0
3	14	15	11	13	17	2.01
4	14	13	13	13	17	0.178
5	13	13	13	12.9	16.8	.026
6	14	17	14	14.6	19	1.70

Table 13: 7 Month for Elm 1

	ppm	ppm	ppm	Average	C. Avg	SD
1	0	0	0	0	0	0
2	0	0	0	0	0	0
3	0	0	0	0	0	0
4	0	0	0	0	0	0
5	0	0	0	0	0	0
6	0	0	0	0	0	0

Table 14: Blank for Elm 2

	ppm	ppm	ppm	Average	C. Avg	SD
1	0	0	0	0	0	0
2	0	0	0	0	0	0
3	0	0	0	0	0	0
4	0	0	0	0	0	0
5	0	0	0	0	0	0
6	0	0	0	0	0	0

Table 15: 72 Hours for Elm 2

	ppm	ppm	ppm	Average	C. Avg	SD
1	17.2	13.2	15.6	15.3	19.9	2.06
2	13.0	16.2	15.8	15	19.5	1.74
3	15.8	14.5	13.4	14.6	18.9	1.22
4	7.9	8.2	11.7	9.3	12.7	2.10
5	15	11.7	13.2	13.3	17.3	1.62
6	14.9	13.6	13.5	14	18.2	.79

Table 16: 1 Month for Elm 2

	ppm	ppm	ppm	Average	C. Avg	SD
1	3.1	3.9	2.6	3.2	6.5	0.69
2	8.5	7.6	8.4	8.2	11	0.50
3	6.7	5.5	4.2	5.4	7.1	1.25
4	1.8	2.3	1.7	1.9	4.7	0.31
5	4.2	3.8	4.1	4.0	8.2	0.23
6	4.2	3.3	5.4	4.3	8.8	1.06

Table 17: 2 Month for Elm 2

	ppm	ppm	ppm	Average	C. Avg	SD
1	23	26.1	20.3	23.1	27.2	3
2	21	27.7	29.2	26	30.6	4
3	7.7	8.9	9.0	8.5	11.7	1
4	22	19.9	26.4	22.9	27.0	3
5	0	0	0	0	0	0
6	5.2	6.0	7.2	6.1	12.5	1

Table 18: 7 Month for Elm 2

	ppm	ppm	ppm	Average	C. Avg	SD
1	10.7	11	11	10.9	14.9	.20
2	10	10.4	11.2	10.5	14.4	.64
3	5.0	5.0	5.0	5.0	6.85	0
4	5.0	5.0	5.0	0	0	0
5	7.9	6.8	7.5	7.41	10.1	.58
6	9.7	9.6	10.1	9.82	13.5	.25

Table 19: Blank for Elm 3

	ppm	ppm	ppm	Average	C. Avg	SD
1	0	0	0	0	0	0
2	0	0	0	0	0	0
3	0	0	0	0	0	0
4	0	0	0	0	0	0
5	0	0	0	0	0	0
6	0	0	0	0	0	0

Table 20: 72 Hours for Elm 3

	ppm	ppm	ppm	Average	C. Avg	SD
1	4.1	3.4	3.6	3.7	7.5	0.34
2	14.1	13.8	12.9	13.6	17.6	0.63
3	2.2	2.8	2.3	2.5	6.2	0.31
4	3.5	4.1	3.4	3.7	7.5	0.40
5	5.0	4.9	5.1	5.0	10.2	0.08
6	4.4	5.4	4.7	4.8	9.8	0.50

Table 21: 1 Month for Elm 3

	ppm	ppm	ppm	Average	C. Avg	SD
1	15.5	17.7	12.8	15.3	19.9	2.46
2	4.2	4.4	5.3	4.6	9.4	0.57
3	17.6	17.0	16.9	17.2	22.3	0.40
4	15.1	16.4	14.0	15.2	19.7	1.19
5	3.3	4.0	3.3	3.5	7.2	0.41
6	9.7	12.3	13.5	11.8	16.2	1.92

Table 22: 2 Month for Elm 3

	ppm	ppm	ppm	Average	C. Avg	SD
1	2.2	3.2	3.8	2.7	5.5	1
2	0	0	0	0	0	0
3	1.3	1.5	1.6	1.5	3.7	0
4	5.7	4.4	5.8	5.3	10.8	1
5	1.4	2.0	2.2	1.9	4.7	0
6	1.3	1.0	1.4	1.3	3.2	0

Table 23: 7 Month for Elm 3

	ppm	ppm	ppm	Average	C. Avg	SD
1	0	0	0	0	0	0
2	0	0	0	0	0	0
3	0	0	0	0	0	0
4	0	0	0	0	0	0
5	0	0	0	0	0	0
6	0	0	0	0	0	0

Table 24: Blank for Elm 4

	ppm	ppm	ppm	Average	C. Avg	SD
1	0	0	0	0	0	0
2	0	0	0	0	0	0
3	0	0	0	0	0	0
4	0	0	0	0	0	0
5	0	0	0	0	0	0
6	0	0	0	0	0	0

Table 25: 72 Hours for Elm 4

	ppm	ppm	ppm	Average	C. Avg	SD
1	8.9	8.0	8.9	8.6	11.8	0.53
2	0	0	0	0	0	0
3	11.5	10.5	10.4	10.8	14.8	0.60
4	2.9	2.4	2.4	2.6	6.4	0.32
5	13.5	13.4	13.6	13.5	18.5	0.11
6	6.3	5.7	4.6	5.5	11.3	0.87

Table 26: 1 Month for Elm 4

	ppm	ppm	ppm	Average	C. Avg	SD
1	6.4	4.7	4.0	5.0	10.3	1.22
2	0	0	0	0	0	0
3	5.8	5.5	5.4	5.6	11.3	0.17
4	3.7	3.8	6.9	4.8	9.8	1.83
5	4.0	4.7	5.9	4.8	9.9	0.98
6	0	0	0	0	0	0

Table 27: 2 Month for Elm 4

	ppm	ppm	ppm	Average	C. Avg	SD
1	0	0	0	0	0	0
2	3.0	3.3	3.7	3.4	6.9	0.35
3	2.6	3.9	3.7	3.4	6.9	0.72
4	2.8	3.1	3.2	3.0	6.1	0.20
5	2.6	2.7	2.8	2.7	5.5	0.09
6	0	0	0	0	0	0

Table 28: 7 Month for Elm 4

	ppm	ppm	ppm	Average	C. Avg	SD
1	0	0	0	0	0	0
2	0	0	0	0	0	0
3	0	0	0	0	0	0
4	0	0	0	0	0	0
5	0	0	0	0	0	0
6	0	0	0	0	0	0

Table 29: Blank for Elm 5

	ppm	ppm	ppm	Average	C. Avg	SD
1	0	0	0	0	0	0
2	0	0	0	0	0	0
3	0	0	0	0	0	0
4	0	0	0	0	0	0
5	0	0	0	0	0	0
6	0	0	0	0	0	0

Table 30: 72 Hours for Elm 5

	ppm	ppm	ppm	Average	C. Avg	SD
1	7.1	6.7	5.6	6.5	13.2	0.73
2	40.0	41.6	44.0	41.9	44.1	2.02
3	42.9	45.5	39.3	42.5	44.8	3.13
4	44.4	48.1	45.7	46	48.5	1.87
5	41.3	41.3	43.4	42	44.2	1.23
6	40.4	41.2	38.8	40.1	42.2	1.22

Table 31: 1 Month for Elm 5

	ppm	ppm	ppm	Average	C. Avg	SD
1	3.3	4.1	3.8	3.7	7.6	0.41
2	33.3	33.6	32.9	33.3	39.1	0
3	35.6	37.7	35.9	36.4	42.8	1.10
4	32.7	33.2	31.6	32.5	38.3	0.82
5	35.6	35.9	36.8	36.1	42.5	0.61
6	31.0	33.4	36.7	33.7	39.6	2.87

Table 32: 2 Month for Elm 5

	ppm	ppm	ppm	Average	C. Avg	SD
1	5.4	3.3	3.6	4.1	8.4	1.1
2	3.8	5.6	3.7	4.4	9.0	0.40
3	14.5	12.9	15.5	14.3	18.6	1.3
4	12.3	13.9	13	13.1	16.9	0.8
5	13.7	11.8	12.8	12.8	16.6	0.9
6	3.1	3.8	3.6	3.5	7.1	0.4

Table 33: 7 Month for Elm 5

	ppm	ppm	ppm	Average	C. Avg	SD
1	12	12	12	12.0	16.51	0.12
2	10	9.6	10.6	10	13.7	0.48
3	13.5	15	14.4	14	18.4	0.57
4	12.1	12.5	12.5	12.40	16.9	0.20
5	10.4	10.5	10.50	10.47	14.34	0.045
6	13	11.5	11.6	12.05	16.5	0.84

Table 34: Blank for Elm 6

	ppm	ppm	ppm	Average	C. Avg	SD
1	0	0	0	0	0	0
2	0	0	0	0	0	0
3	0	0	0	0	0	0
4	0	0	0	0	0	0
5	0	0	0	0	0	0
6	0	0	0	0	0	0

Table 35: 72 Hours for Elm 6

	ppm	ppm	ppm	Average	C. Avg	SD
1	3.0	3.5	3.3	3.3	11.6	0.30
2	4.8	5.3	3.8	4.6	9.7	0.79
3	4.0	3.6	4.0	3.9	5.2	0.24
4	2.2	2.0	2.1	2.1	5.3	0.13
5	0	0	0	0	9.4	0.0
6	4.2	3.7	3.8	3.8	9.5	0.39

Table 36: 1 Month for Elm 6

	ppm	ppm	ppm	Average	C. Avg	SD
1	3.0	2.4	2.9	2.7	6.9	0.32
2	0	0	0	0	0	0
3	0	0	0	0	0	0
4	0	0	0	0	0	0
5	0	0	0	0	0	0
6	0	0	0	0	0	0

Table 37: 2 Month for Elm 6

	ppm	ppm	ppm	Average	C. Avg	SD
1	0	0	0	0	0	0
2	0	0	0	0	0	0
3	0	0	0	0	0	0
4	0	0	0	0	0	0
5	0	0	0	0	0	0
6	0	0	0	0	0	0

Table 38: 7 Month for Elm 6

	ppm	ppm	ppm	Average	C. Avg	SD
1	0	0	0	0	0	0
2	0	0	0	0	0	0
3	0	0	0	0	0	0
4	0	0	0	0	0	0
5	0	0	0	0	0	0
6	0	0	0	0	0	0

Table 39: Blank for Old Security Elm

	ppm	ppm	ppm	Average	C. Avg	SD
1	0	0	0	0	0	0
2	0	0	0	0	0	0
3	0	0	0	0	0	0
4	0	0	0	0	0	0
5	0	0	0	0	0	0
6	0	0	0	0	0	0

Table 40: 72 Hours for Old Security Elm

	ppm	ppm	ppm	Average	C. Avg	SD
1	0	0	0	0	0	0
2	0	0	0	0	0	0
3	0	0	0	0	0	0
4	0	0	0	0	0	0
5	0	0	0	0	0	0
6	0	0	0	0	0	0

Table 41: 1 Month for Old Security Elm

	ppm	ppm	ppm	Average	C. Avg	SD
1	7.4	7.6	6.7	7.3	14.8	0.50
2	8.8	10.0	9.7	9.5	13.0	0.60
3	8.2	8.7	9.4	8.8	12	0.58
4	10.8	10.8	11.7	11.1	15.2	0.51
5	9.6	8.5	10.0	9.4	19.1	0.74
6	7.5	7.3	7.8	7.6	15.4	0.26

Table 42: 2 Month for Old Security Elm

	ppm	ppm	ppm	Average	C. Avg	SD
1	0	0	0	0	0	0
2	0	0	0	0	0	0
3	0	0	0	0	0	0
4	0	0	0	0	0	0
5	0	0	0	0	0	0
6	0	0	0	0	0	0

Table 43: 7 Month for Old Security Elm

	ppm	ppm	ppm	Average	C. Avg	SD
1	0	0	0	0	0	0
2	0	0	0	0	0	0
3	0	0	0	0	0	0
4	0	0	0	0	0	0
5	0	0	0	0	0	0
6	0	0	0	0	0	0

Table 44: Blank for Ford Residential Elm

	ppm	ppm	ppm	Average	C. Avg	SD
1	0	0	0	0	0	0
2	0	0	0	0	0	0
3	0	0	0	0	0	0
4	0	0	0	0	0	0
5	0	0	0	0	0	0
6	0	0	0	0	0	0

Table 45: 72 Hours for Ford Residential Elm

	ppm	ppm	ppm	Average	C. Avg	SD
1	2.0	2.4	2.3	2.2	5.6	0.18
2	2.2	2.2	2.4	2.3	5.7	0.10
3	0	0	0	0	0	0
4	26.6	24.2	27.3	26	30.6	1.64
5	0	0	0	0	0	0
6	0	0	0	0	0	0

Table 46: 1 Month for Ford Residential Elm

	ppm	ppm	ppm	Average	C. Avg	SD
1	0	0	0	0	0	0
2	0	0	0	0	0	0
3	0	0	0	0	0	0
4	0	0	0	0	0	0
5	0	0	0	0	0	0
6	0	0	0	0	0	0

Table 47: 2 Month for Ford Residential Elm

	ppm	ppm	ppm	Average	C. Avg	SD
1	0	0	0	0	0	0
2	0	0	0	0	0	0
3	0	0	0	0	0	0
4	0	0	0	0	0	0
5	0	0	0	0	0	0
6	0	0	0	0	0	0

Table 48: 7 Month for Ford Residential Elm

	ppm	ppm	ppm	Average	C. Avg	SD
1	0	0	0	0	0	0
2	0	0	0	0	0	0
3	0	0	0	0	0	0
4	0	0	0	0	0	0
5	0	0	0	0	0	0
6	0	0	0	0	0	0

Table 49: Blank for 40 mL Ford Residential Elm

	ppm	ppm	ppm	Average	C. Avg	SD
1	0	0	0	0	0	0
2	0	0	0	0	0	0
3	0	0	0	0	0	0
4	0	0	0	0	0	0
5	0	0	0	0	0	0
6	0	0	0	0	0	0

Table 50: 72 Hours for 40 mL Ford Residential Elm

	ppm	ppm	ppm	Average	C. Avg	SD
1	3.8	3.7	3.5	3.7	7.5	0.17
2	6.8	3.8	4.6	5.1	10.4	1.57
3	51.4	52.5	51.4	51.8	54.5	0.63
4	4.2	3.9	4.7	4.3	8.7	0.41
5	10.9	9.6	9.9	10.1	13.9	0.65
6	4.9	4.6	4.5	4.7	9.5	0.21

Table 51: 1 Month for 40 mL Ford Residential Elm

	ppm	ppm	ppm	Average	C. Avg	SD
1	28.4	29.0	30.1	29.2	34.3	0.9
2	10.5	11.4	11.0	11.0	15.1	0
3	7.0	6.5	6.5	6.7	13.7	0.3
4	11.7	12.0	12.3	12.0	16.4	0.3
5	12.6	12.6	12.4	12.5	17.2	0.1
6	11.6	11.5	11.4	11.5	15.8	0.1

Table 52: 2 Month for 40 mL Ford Residential Elm

	ppm	ppm	ppm	Average	C. Avg	SD
1	16.8	16.9	17	16.9	21.0	0.1
2	10.7	11.3	11.8	11.3	15.4	0.3
3	10.3	10.8	9.7	10.3	14.2	0.5
4	5.1	4.8	7.2	5.7	12.0	1.2
5	6.5	6.5	6.5	6.5	13.3	0
6	5.5	5.8	6.0	5.7	11.0	0.3

Table 53: 7 Month for 40 mL Ford Residential Elm

	ppm	ppm	ppm	Average	C. Avg	SD
1	10.2	8.9	8.9	9.4	12.8	0.8
2	11.2	11.2	9.5	10.7	14.6	0
3	12	13.3	12.9	12.7	17.4	0.7
4	5.0	5.0	5.0	5.0	10.2	0
5	8.7	8.7	8.7	8.7	12.0	0
6	8.3	7.8	7.4	7.8	10.7	0.5

Chapter IX

Vita

Stephanye Dawn Armstrong was born in Winston-Salem, North Carolina on May 19th, 1971. She received her Bachelors of Science in Chemistry from Winston-Salem State University in 1993 and a Masters Degree in Chemistry from Virginia Polytechnic Institute and State University in 1995. She is planning to graduate with a Ph.D. from Virginia Tech in June 1999 and start a career in industrial research involving chromatographic techniques.